

# **Headstart by VENDEX**

## **TURBO-888-XT SERVICING GUIDE**

# Table of Contents

## 1. Introduction

About This Manual . . . . .	1--1
Associated Documentation . . . . .	1--1
Standard System Configuration . . . . .	1--2
Required Tools and Supplies . . . . .	1--3

## 2. Advanced System Diagnostics

1. Purpose . . . . .	2--5
2. Scope . . . . .	2--5
3. Definition of Acceptable Quality Level . . . . .	2--5
4. Sample Size and Accept/Reject Quantities . . . . .	2--6
5. Reliability Testing Requirements . . . . .	2--6
6. Inspection Procedures . . . . .	2--7
7. Classification of Defects . . . . .	2--8
8. Environment of Audit Inspection . . . . .	2--8
9. Selection of Defects . . . . .	2--9
10. General Inspection Procedures . . . . .	2--9
11. Defect Classification Table . . . . .	2--11
12. VENDEX Computer Inspection Test Procedure . . . . .	2--14
12.1. Related Documents . . . . .	2--14
12.2. Test Equipment . . . . .	2--14
12.3. Defect Classification References . . . . .	2--15
12.4. Visual Inspection . . . . .	2--15
12.4.1. Packaging Inspection . . . . .	2--15
12.4.2. Top Cover Inspection . . . . .	2--16
12.4.3. Bottom Inspection . . . . .	2--16
12.4.4. PCBA Inspection . . . . .	2--16
12.4.5. Power Supply Inspection . . . . .	2--17
12.4.6. Wiring and Cable Inspection . . . . .	2--18
12.4.7. Back and Sides Inspection . . . . .	2--18
12.4.8. General Inspection . . . . .	2--18
12.4.9. Keyboard Inspection . . . . .	2--19
12.4.10. LED Color Inspection . . . . .	2--19
12.5. Functional Test Inspection . . . . .	2--19
12.5.1. Continuity and Grounding Test . . . . .	2--19
12.5.2. Power Up Sequence . . . . .	2--20
12.5.3. Power Supply Test . . . . .	2--20
12.5.4. Boot Disk # 1 . . . . .	2--20
12.5.5. Alignment Test . . . . .	2--21

12.5.6. Functional Test Setup	2--25
12.5.7. Light Pen Test	2--25
12.5.8. Mouse Test	2--26
12.5.9. Memory Test	2--27
12.5.10. Parallel Port Test	2--30
12.5.11. RS-232 Serial Port Test	2--31
12.5.12. Keyboard Test	2--33
12.5.13. Video Display Test	2--34
12.5.14. Diskette Test	2--35
12.5.15. Clock Speed Switch Test	2--38
12.5.16. DMA Controller Test	2--39
12.5.17. Joystick Test	2--41
12.6. Final System Button Up	2--44
12.7. Software Inspection	2--45
<b>13. Monochrome Monitor Inspection Procedure</b>	<b>2--48</b>
13.1. Related Documents	2--48
13.2. Test Equipment	2--48
13.3. Visual Inspection	2--48
13.4. Labels	2--49
13.5. Packaging	2--49
13.6. Test Inspection	2--49
13.6.1. Function Test 1	2--50
13.6.2. Function Test 2 (Focus)	2--50
13.6.3. Function Test 3 (High Resolution)	2--51
13.6.4. Function Test 4 (Low Intensity)	2--51
13.6.5. Function Test 5 (High Voltage Resolution)	2--51
13.6.6. Function Test 6 (Linearity and Focus)	2--51
13.6.7. Picture Brightness	2--51
13.6.8. Tap Test	2--52
13.6.9. Test Completion	2--52
<b>14. Monochrome Monitor Inspection Procedure</b>	<b>2--53</b>
14.1. Related Documents	2--53
14.2. Test Equipment	2--53
14.3. Visual Inspection	2--53
14.4. Labels	2--54
14.5. Packaging	2--54
14.6. Test Inspection	2--54
14.6.1. Red Color and Purity Test	2--55
14.6.2. Green Color and Purity Test	2--55
14.6.3. Blue Color and Purity Test	2--55
14.6.4. High Voltage Regulation	2--55
14.6.5. Focus Test	2--55
14.6.6. Color and Contrast (16 Color)	2--56
14.6.7. Jitter Test	2--56
14.6.8. Picture Size	2--56
14.6.9. Misconvergence	2--56

14.6.10. Brightness . . . . .	2--57
14.6.11. White Balance . . . . .	2--57
15. VENDEX Computer Inspection Test Procedure . . . . .	2--58
16. Monochrome Monitor Inspection Procedure . . . . .	2--60
17. Color Monitor Inspection Procedure . . . . .	2--61

### 3. Problem Isolation Inspection

Introduction . . . . .	3--1
PCBA Inspection . . . . .	3--1
Power Supply Inspection . . . . .	3--2
General Inspection . . . . .	3--2
Keyboard Inspection . . . . .	3--2

### 4. Problem Isolation Procedure

Introduction . . . . .	4--1
Power-On Self Test . . . . .	4--1
Power-On Self Test Errors . . . . .	4--1
Problem Solving Questions . . . . .	4--2
Error Messages and Solutions . . . . .	4--3
CPU Tests . . . . .	4--4
CPU Board Specifications . . . . .	4--4
CPU Switch Settings . . . . .	4--7
Video Display Adapters . . . . .	4--8
Checking Out the Video Display . . . . .	4--10
Power Supply . . . . .	4--11
Power Supply Specifications . . . . .	4--13
Motherboard . . . . .	4--15
Mother Board Expansion Slot Specifications . . . . .	4--16
Real-Time Clock . . . . .	4--19
Specifications . . . . .	4--19
Keyboard Specifications . . . . .	4--20
Printer Adapter (Centronics Standard, Parallel Port) . . . . .	4--21
5 1/4" Disk Drive Controller . . . . .	4--22
Disk Adapter . . . . .	4--23
Connector Specification . . . . .	4--24
Diskette Drive Specifications . . . . .	4--25
Asynchronous Communication Port (Serial Port) . . . . .	4--27
Serial Port . . . . .	4--29
ESI RS232 Serial Port Test Plug . . . . .	4--29
Parallel Port . . . . .	4--29
ESI Parallel Port Test Plug . . . . .	4--29
Parts List for the TURBO-888-XT . . . . .	4--30

## 5. External and Internal View

Locations	5--1
System Unit	5--1
Front Panel	5--2
System Unit Interior View	5--3
Rear Panel	5--4
Keyboard	5--5

## Figures

1-1. Standard System Configuration	1--2
4-1. CPU Board Test Flow Chart	4--4
4-2. CPU Figure Parts Arrangement Plan	4--5
4-3. CPU Board	4--6
4-4. Power Supply Test Flow Chart	4--12
4-5. Mother Board Figure Parts Arrangement Plan	4--17
4-6. Mother Board Test Flow Chart	4--18
4-7. Real-Time Clock Block Diagram	4--19
4-8. Fixed Disk Adapter Block Diagram	4--23
4-9. Asynchronous Communication Port Block Diagram	4--27
5-1. VENDEX Turbo 888-XT Standard System Configuration	5--1
5-2. Front Panel	5--2
5-3. Internal View of System Unit	5--3
5-4. Rear Panel of System Unit	5--4
5-5. Keyboard	5--5

## Tables

4-1. Power Connector Pinouts	4--11
4-2. DC Output	4--13
4-3. Mother Board Pinouts	4--16
4-4. Keyboard Interface Connector	4--20
4-5. Parallel Port Pinouts	4--21
4-6. Diskette Drive Controller Pinouts	4--24
4-7. Diskette Drive Power Requirements	4--26
4-8. Serial Port Connector Pinouts	4--28

# Chapter 1. Introduction

## About This Manual

This manual is a troubleshooting, maintenance guide for servicing the VENDEX Headstart Turbo-888-XT.

The manual is divided into five chapters which are briefly described below:

**Chapter 1. Introduction** contains a description of the contents and organization of this manual. It includes a description and illustration of the VENDEX Turbo XT-888 standard configuration and provides a list of tools that will be required to perform the various tests described in this book.

**Chapter 2. Advanced System Diagnostics** provides step-by-step instructions for performing each of the diagnostic tests.

**Chapter 3. Problem Isolation Inspection** provides instructions for performing a physical inspection of each of the system components.

**Chapter 4. Problem Isolation Procedure** provides a list of errors that may occur and solutions for correcting the errors.

**Chapter 5. External and Internal View** contains location drawings for the various system components.

## Associated Documentation

Other documents which may be useful for servicing the TURBO-888- XT include:

The VENDEX Headstart Operating Manual including the following sections:

- Getting Started
- VENDEX Headstart Operating Environment
- HOT (tm) Desktop Pop-Up Services
- MS-DOS 3.2 User's Guide and User's Reference Guide
- Technical Appendixes

# Chapter 1

---

## Standard System Configuration

- The standard configuration for the VENDEX Turbo 888-XT is as follows:
- 8088-2 dual speed Turbo (4.77/8 MHz) microprocessor
- 512K standard memory, expandable to 768K
- Two 360KB double-sided, double-density disk drives
- Color card with monochrome, Hercules, or RGB color capability
- Real-time clock with Nicad re-chargeable battery
- Seven expansion slots, two utilized by system option boards, five available for additional user expansion
- One parallel printer port
- One asynchronous serial port
- Bus mouse port
- Game port
- Light pen port
- 32K RAM disk (expanded to 112K when system has 768K RAM installed)
- Printer buffer (available when system has 768K RAM installed)
- Keyboard
- Monitor

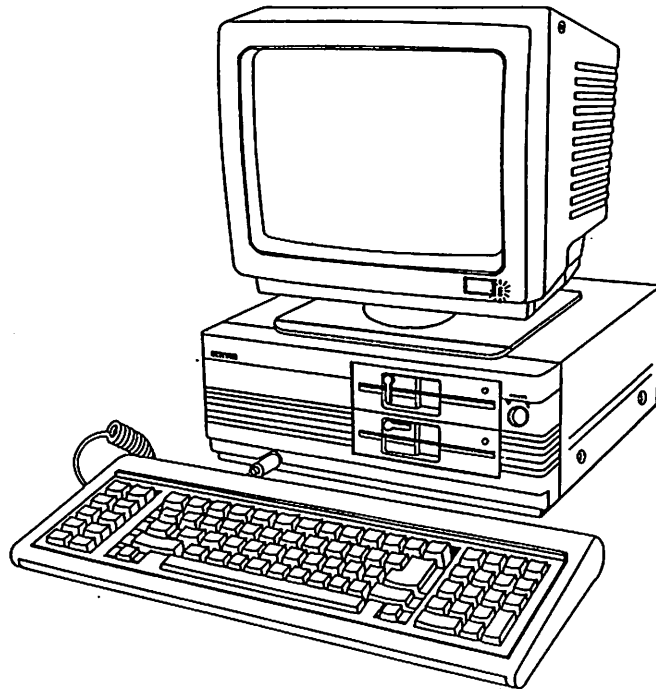

Figure 1-1. Standard System Configuration

## **Introduction**

---

### **Required Tools and Supplies**

The following tools and supplies are required for servicing the VENDEX Turbo-888-XT.

- Phillips Screw Driver
- Formatted Scratch Diskette(s)
- Wrap Plug (Serial - see page 4-29)
- Wrap Plug (Parallel - see page 4-29)
- Volt/OHM meter
- Alignment Diskette (Dysan DDD Model #508-4000)
- Alignment Program Diskette (Dysan Interrogator)
- VENDEX Advanced Diagnostic Diskette
- Light Pen
- Joy Stick



## **Chapter 2. Advanced System Diagnostics**

**This chapter is taken from the Customer Audit Inspection Procedure for VENDEX Turbo-888-XT computers and monitors. The tests included in this chapter can be used to diagnose and solve problems related to the various components of the Turbo-888-XT system.**

**Since this section is borrowed in total from the Audit Inspection document, the page numbering and page formatting for this chapter are unique. However, both the index and the table of contents for this chapter are shown with the chapter number "2" preceding the page number.**

## 1 PURPOSE

This document establishes general testing and defect rating criteria to be used during the customer audit inspection procedure for the VENDEX HeadStart computer system components consisting of personal computers, monochrome monitors, and color monitors. This general layout of criteria is specified so that a uniform and consistent quality inspection program can be administered by VENDEX. This will apply both at the manufacturers factory and at the test sites selected for state side incoming product inspection.

This document shall be the governing document in determining pass/fail criteria on customer audit inspections of the VENDEX products. From time to time this document will be amended to change existing procedures or to include additional procedures as is determined to be necessary to maintain the highest quality product. Decisions concerning modifications to this document must be made by authorized VENDEX officials or its assigned agents.

This document also specifies the detailed inspection procedure steps for the visual and functional testing of the computers and monitors.

## 2 SCOPE

This standard encompasses the full range of attribute characteristics for the VENDEX HeadStart TURBO 888-XT computer, the VENDEX M-888-M monochrome monitor, and the VENDEX M-888-C RGB color monitor.

## 3 DEFINITION OF ACCEPTABLE QUALITY LEVEL

The acceptable quality level (AQL) is the maximum percent defective (or the maximum number of defects per hundred units) that, for purposes of sampling inspection, can be considered satisfactory as a process average.

VENDEX has designated some specific values of AQL for certain groups of defects, and this indicates to the supplier that VENDEX's acceptance sampling plan will accept the great majority of the lots or batches that the supplier submits, provided the process average level of percent defective (or defects per hundred units) in these lots or batches be no greater than the designated value of AQL. Thus, the AQL is a designated value of percent defective (or defects per hundred units) that VENDEX indicates will be accepted most of the time by the acceptance sampling procedure to be used. The sampling plans provided in MIL-STD-105D are so arranged that the probability of acceptance at the designated AQL value depends upon the sample size, being generally higher for large samples than for small ones, for a given AQL. The AQL alone does not describe the pro-

tection to VENDEX for individual lots or batches but more directly relates to what might be expected from a series of lots or batches, provided the steps indicated are taken. It is necessary to refer to the operating characteristics curve of the plan, to determine what protection VENDEX will have.

The acceptable quality level (AQL) that shall be permitted during the inspection process defines the percentage of failures that will be allowed without rejection of the factory outgoing lot or stateside incoming lot. The following tabulation shows the AQL levels that will be permitted by this documented standard.

Failure Class	(AQL) Percentage
Critical (A)	0.0 %
Major (B)	1.5 %
Minor (C)	4.0 %

**4 SAMPLE SIZE AND ACCEPT/REJECT QUANTITIES**

The following table specifies the computer or monitor shipping lot size and the corresponding customer audit inspection sample size. The last four columns specify the number of sample units that can be accepted with specific types of defects or will cause rejection of the whole lot.

**LOT SIZE ACCEPT/REJECT**

LOT SIZE	SAMPLE SIZE	AQL 1.5		AQL 4.0	
		ACCEPT	REJECT	ACCEPT	REJECT
91- 150	20	0	1	2	3
151- 280	32	1	2	3	4
281- 500	50	2	3	5	6
501- 1200	80	3	4	7	8
1201- 3200	125	5	6	10	11
3201-10000	200	7	8	14	15

**5 RELIABILITY TESTING REQUIREMENTS**

The customer audit inspections of computers and monitors by VENDEX shall include a number of reliability tests to further enhance the overall product quality monitoring. The number of units tested will be dependent upon the sample lot size as defined above. These tests will be done prior to the normal inspection and functional test procedures. The tests include computers, monochrome monitors, and color monitors.

SAMPLE SIZE	DROP TEST	VIBRATION TEST	BURN-IN TEST	HI-POT TEST
20	1	1	2	2
32	1	1	3	3
50	2	2	4	4
80	4	4	6	6
125	5	5	10	10
200	7	7	15	15

Drop testing is to be performed in the shipping carton to the NSTA specifications contained in an attachment to this document.

Vibration testing is also to be performed to NSTA specifications.

Burn-In (aging) is an elevated temperature long term testing. The test samples are to be burned-in (aged) in a static non-operating mode for 72 hours at a temperature of 50 C. During the burn-in the units should be ON and powered with an input AC line voltage of 132 VAC.

The HI-POT test is a high voltage application to the sample unit to ensure that it can withstand high voltage transients without loss of function. This test is performed using a KIKUSUI tester Model # 875Z or equivalent. Two tests are performed. The (+) terminal of the HI-POT tester is connected to the AC power cord ground to the unit. The (-) terminal of the HI-POT tester is connected to the two AC input leads of the unit.

HI-POT Test # 1      Apply a DC voltage of 1400 V in a pulse of 60 seconds duration with the current flow limited to 10 milliamperes.

HI-POT Test # 2      Apply a AC voltage of 1200 V in a pulse of 1 second duration with the current flow limited to 10 milliamperes.

The Hi-POT test shall normally be performed on selected sample units after the initial packaging and cosmetic inspections. After the HI-POT test the test units are then subjected to the normal internal and functional testing procedures.

## 6 INSPECTION PROCEDURES

This inspection procedure will follow the guide lines set forth in the USA MIL-STD-105D document of which applicable sections are included as an attachment to this document. The procedure will use a single sampling plan of general inspection at Level II.

## 7 CLASSIFICATION OF DEFECTS

All of the various types of defects will be classified into three categories. An acceptable quality level (AQL) is used to define the quantities of acceptable defects in an inspection lot for each category. The three categories are defined below:

### CLASS A - Critical Defect

This class of defects includes all defects which are or can result in a safety hazard in the handling, installation or use of the computers or monitors. These defects are listed in the defect classification tables by the letter "A".

### CLASS B - Major Defect

This class includes defects which cause the computer or monitor to be completely unusable, non-functional, or unsellable. Major defects also include all those which cause the computer or monitor to be partially non-functional rendering it unsellable and/or unusable until it has been repaired and is tested as operational. These defects are listed in the defect classification tables by the letter "B".

### CLASS C - Minor Defect

A minor defect, in this category, is defined as a defect that does not substantially limit the use of the computer or the monitor for its intended function. A minor defect is also defined such that it is very unlikely that it could develop into to a major type of defect if correction is neglected. This type of defect is listed in the defect classification tables by the letter "C".

## 8 ENVIRONMENT OF AUDIT INSPECTION

This inspection standard and procedure is applied to the VENDEX computers and monitors in the environment of normal use for the intended function. The environment of testing will utilize software and specific hardware peripheral attachments that validate the computer and monitor functions. The use of oscilloscopes or detailed meter measurements is not a part of the procedure unless specifically specified in a procedure step.

### Temperature and Humidity

The ambient temperature of the room and equipment during the inspection process must be between 10 C to 25 C at 50 to 75 percent humidity unless otherwise specified.

### Intensity of Illumination

The inspection area must be illuminated with overhead fluorescent lighting that emits light intensity of 400 to 700 luxes.

### Visual Inspection Distance

All visual inspection is to be performed at a nominal distance of 45 centimeters with the naked eye. Certain inspection details will obviously require a different distance in order to perform the task. The inspector shall personally adjust the visual inspection distance to less than 45 centimeters depending upon visual capability and/or detail of inspection step.

## 9 SELECTION OF DEFECTS

In the case that multiple defects are found in a single computer or monitor the first found defect with the highest severity rating (Class A highest to Class C lowest) will determine the accept/reject criteria and rating for that particular unit. The inspection, however, must proceed as far through the inspection procedure as possible and all located defects must be recorded in the inspection report.

## 10 GENERAL INSPECTION PROCEDURES

The following list of procedures defines the required inspection activities. The customer audit inspectors will check these items in the order specified. Any non-conforming items (defects or deviations) shall be classified according to the defect classification charts in the following section. A lot inspection report shall then be prepared using one or more sheets of the form attached in Appendix A. The individual inspectors shall then submit the inspection reports to the VENDEX customer audit inspection supervisor for approval and transmission to VENDEX.

A) Count the full lot of computers or monitors and ensure that the quantity of units corresponds 100 % to the reported lot size on the appropriate shipping and/or lot tracking documentation.

- B) Verify that 100 % of all equipment shipping cartons are the right style of VENDEX boxes, that they are sealed properly, and are ready for shipment.
- C) Verify that 100 % of the shipping cartons are marked with the unit serial number on the outside of the box. Ascertain that all of the units have the proper sequence of serial numbers and that this lot of serial numbers are unique (ie, not duplicated from prior shipments). Also determine that the lot is marked properly for the intended shipping destination.
- D) Perform random selection of inspection samples and mark the sampled cartons according to standard marking practice. The quantity of samples shall be determined from information in MIL STD 105D for single sample Level II inspection and as presented in Section 4.
- E) Perform detailed inspection of the packing cartons for each sample unit. This includes consideration of padding material, bags, sealing method, and equipment orientation inside the carton. The visual appearance of the carton, inside and out must be evaluated.
- F) View the cosmetics of each sample unit from the outside looking for deviations and defects such as paint color, surface flaws, and sharp edges etc, markings and labels.
- G) Arrange the necessary drop testing, vibration testing, burn-in and HI-POT testing of selected sample units from the lot. These units shall, after the various special tests specified above, then be inspected to the remainder of the steps given below.
- H) Remove the cover or case of each sample unit and perform internal visual inspection, including attention to appearance, neatness, mechanical integrity, component and subassembly mounting. Check for secure hardware and I/O connection points.
- I) Perform functional test of each sample unit utilizing the appropriate test procedure as described in the latter parts of this document.

11 DEFECT CLASSIFICATION TABLE

This section lists the presently determined set of defect descriptions and their corresponding defect severity classifications. This list may be appended or modified from time to time as inspection experience dictates the need for changes. Such changes may only be made by VENDEX authorized persons or their duly authorized agents.

PACKING RELATED DEFECTS (Defect Codes "Ax")

Defect Code	Description	Defect Category
A1	Incorrect marking or stamping	C
A2	Missing accessories	B
A3	Missing polyfoam	B
A4	Reverse packing	C
A5	Missing polybag	C
A6	Incorrect/missing serial number,model name	B
A7	Damaged carton box (requiring replacement)	B
A8	Foreign material in carton:	
ASA	-that may damage the unit	B
ASB	-that may not damage the unit	C
A9	Wrong color	C
A10	Polyfoam broken/severe distorted	C
A11	Missing Floppy Drive Cardboard Insert	B



**COSMETIC RELATED DEFECTS (Defect Codes "Bx")**

Defect Code	Description	Defect Category
B1	The following miscellaneous defects shall not be noticeable by the user during normal operation of the equipment when viewed from a distance of approximately 45 centimeters from the top and front or 90 centimeters from the sides and back. This applies to viewing for 10 to 15 seconds in a simulated office environment where the light intensity is from 400 to 700 luxes.	
B1A	-chips, nicks, or burrs	C
B1B	-scratches over 1x1x5 mm (top & front)	C
B1C	-scratches over 1*1*10mm (side & back)	C
B2	Foreign material or dirty case (glue, tape, paint, etc.)	
B2A	-that can be cleaned	C
B2B	-that can not be cleaned	B
B3	Wrong color:	
B3A	-unsellable	B
B3B	-sellable	C
B4	Gaps:	
B4A	-front and top cover over 1.5 mm	C
B4B	-front and FDD bezel over 1.5 mm	C
B5	Severe damaged or cracked cover (front,top)	B
B6	missing label:	
B6A	-UL/CSA/FCC	A
B6B	-Model or Serial number	B
B6C	-other label	C
B7	Oxidation of the metal parts	B
B8	Missing rubber foot on the bottom	B
B9	Bent or damaged hardware	B
B10	Wrong hardware	B

**FUNCTIONAL OPERATION RELATED DEFECTS (Defect Codes "Cx")**

Defect Code	Description	Defect Category
C1	Does not power on	B
C2	Any electrical intermittent	B
C3	Mechanical shock failure	B
C4	Wrong/missing keycap	B
C5	Any function failure	B
C6	RTC test	B
C7	BIOS Diagnostic test	B
C8	Memory test	B
C9	Parallel port test	B
C10	RS-232C test	B
C11	Keyboard test	B
C12	Video display test	B
C13	Disk test	B
C14	Mouse test	B
C15	Joystick test	B
C16	Lightpen test	B
C17	Alignment of FDD test	B
C18	DMA Controller test	B
C19	Software Diskette	B

**INTERNAL VISUAL INSPECTION RELATED DEFECTS (Defect Codes "Dx")**

Defect Code	Description	Defect Category
D1	Any missing screws	B
D2	Loose or damaged screws	B
D3	Foreign material:	
D3A	-conductive over 3 mm (any dimension)	B
D3B	-conductive under 3 mm (all dimension)	C
D3C	-nonconductive	C
D3D	-obstruction to fan	B
D3E	-obstruction to FDD	B
D3F	-obstruction to J1-J7 connectors	B
D4	Wrong revision of BIOS firmware	B
D5	Cold solder (more than 3 points)	B
D6	Blow hole, pin hole (more than 10 points)	C
D7	Missing components/hardware	B
D8	Loose components	B
D9	Wiring/harness routing and connectors	C
D10	Bad wire crimps in connectors	B

## 12 VENDEX COMPUTER INSPECTION TEST PROCEDURE

This section is provided for the testing and inspection of the VENDEX Personal Computer. It specifies the exact sequence of procedures to allow a careful and uniform inspection of sample test units.

This procedure defines the test and inspection requirements, criteria for acceptance and rejection both visual and functional for the VENDEX Head Start System Turbo-888-XT.

### 12.1 RELATED DOCUMENTS

The following documents are relevant information to this inspection procedure. Excerpts from items A and B are included as attachments to this document. Item C is Attachment A to this document.

- A. NSTA Specification (National Safe Transit Authority)
- B. MIL STD-105D
- C. VENDEX Inspection Report Form
- D. MIL HDBK-53

### 12.2 TEST EQUIPMENT

The following test equipment is necessary to perform the test and inspection of the VENDEX computer. In all cases items equivalent in function and quality to those listed may be utilized for the test.

A special note applies to the Dysan DDD diskettes. These have a useful life of 50 to 100 tests. After this useful life the read amplitude of the signals recorded on the alignment diskette degrade and reduce the accuracy of the DDD. This specification thus specifies that a new DDD be utilized for each inspection lot of 50 to 100 sample units. A single new DDD may be utilized for two inspection lots if the number of sample units in each lot is below 50 units.

- A. Volt Ohm Meter - Hewlett Packard Model 3468A
- B. Diagnostics Disk - Auto load software diskette provided by ESI
- C. Alignment Diskette - Dysan DDD Model # 508-400
- D. Alignment Program Disk - Dysan Interrorgater Version 2.05
- E. Serial Interface Test Loopback Connector

- F. Parallel Interface Test Loopback Connector
- G. Monochrome Monitor - VENDEX M-888-M
- H. Color Monitor - VENDEX M-888-C
- I. Light Pen - Kurta, Pen mouse
- J. Joy Sticks - C.H. Products, Mach III (2ea)
- K. Mouse - Microsoft Bus Mouse
- L. Keyboard overlay
- M. Digital Wall Clock - Set to New York USA time
- N. Hard Disk Based XT-888 setup for Diskette Inspection

### 12.3 DEFECT CLASSIFICATION REFERENCES

Through out this procedure references to the defect classification tables of Section 11 will be made. These are listed as two codes in {} as shown below. A failure encountered during the particular inspection procedure step would generally be classified according to the code in the {}. The first code is the defect code number while the second is the defect category.

{A1}{C}

This symbol represents a defect listed as "Incorrect Marking or Stamping" that falls into the "C" defect category for minor defects.

### 12.4 VISUAL INSPECTION

This is a procedure of steps to check a number of items related to the computer product that can be performed by a visual review.

#### 12.4.1 Packaging Inspection

- A. Ensure the outer carton is the correct VENDEX container. {A9}{C}
- B. Ensure the correct packing material has been used. {A5}{C}
- C. Ensure the computer has been wrapped in a plastic bag. {A5}{C}
- D. Ensure the keyboard has been wrapped in a plastic bag. {A5}{C}

- E. Ensure the box containing the software and documentation is packed and all the documentation is in the box. {A2}{B}
- F. Ensure the AC power cord is included in the box and that the computer is tested with the AC power cord that is to be shipped with the computer. {A2}{B}
- G. Ensure that the safety registration labels are attached to the AC power cord. (UL/CSA) {B6}{A}
- H. Ensure that both floppy disk drives have cardboard inserts. {A11}{B}

#### 12.4.2 Top Cover Inspection

- A. For this inspection the top cover of the computer must be removed. Remove the five screws securing the top cover, then remove the top cover.
- B. Ensure there are no dents or scratches on the top cover. {B1}{C}
- C. Check the inside of the top cover and ensure there is no paint around the mounting holes in five places. {A9}{C}
- D. Ensure the front bezel mounting hardware is tight. {D2}{B}
- E. Check that the VENDEX logo is correct. {B6}{C}
- F. Verify that the paint color of the top cover matches that of the bezel and the floppy disk bezels. {B3}{B}

#### 12.4.3 Bottom Inspection

- A. Check the bottom cushions/feet (4ea), ensure they are tight and the washers are installed. {B8}{B}

#### 12.4.4 PCBA Inspection

- A. Ensure that all PCBA's are installed properly and all hardware is secure. {D2}{B}
- B. Ensure the ITI Video PCBA is installed in J1 slot.
- C. Check the jumpers on the ITI Video board for proper position. The proper positions are listed below. {C5}{B}

JP1 up  
 JP2 down  
 JP3 down  
 JP4 down  
 JP5 up  
 JP6 up  
 JP7 up  
 JP10 up

- D. Check the game port bracket with connectors, covers J2 rear panel slot.
- E. Verify that the CPU PCBA is installed in the J3 slot. Make sure the speaker and keyboard connector cables are attached. Check the CPU board DIP switch settings according to the table below. {C5}{B}

**CPU Board DIP Switch Settings**

1 OFF  
 2 ON  
 3 OFF  
 4 OFF  
 5 ON  
 6 ON  
 7 OFF  
 8 ON

- F. Ensure that a small label on the switch block specifies the switch numbers as 1 through 8 with 1 being toward the front of the computer. {B6}{B}
- G. Ensure the PCBA's are fully seated. {C5}{B}
- H. Check all components for proper installation including proper lead length, crystals attached to PCBA's with adhesive or tape, and larger capacitors are securely attached without damage. {C5}{B}
- I. Check the J1 to J7 connectors mounted on the mother board for bent or missing pins or entrapped foreign material. {C5}{B}

**12.4.5 Power Supply Inspection**

- A. Ensure the power supply is mounted properly and all hardware is secure. Check the power cable, ensure it is routed properly and connector is tight. {C5}{B}
- B. Check all wire crimps. {C5}{B}

**12.4.6 Wiring and Cable Inspection**

- A. Ensure all cables and wires are routed properly and connectors are seated properly. {D9}{C}

**12.4.7 Back and Sides Inspection**

- A. Ensure that the safety registration labels are attached to the computer. (UL/CSA/FCC) {B6}{A}
- B. Ensure that the Model/Serial Number label is installed properly. {B6}{B}
- C. Ensure there is no paint around the top cover mounting holes. {C5}{B}
- D. Ensure the installation of the other labels on the back of the computer. Verify the VENDEX logo with S/N and Main Power Input and Output voltage labels. {B6}{B}
- E. Ensure the Hex screws on the back are tight (x10), and ensure the Hex screws are threaded internally. {D2}{B}
- F. Check that the top cover has bare metal to metal contact when mounted to the PC chassis. The spring clips on the floppy disk mounting brackets or the the floppy disk mounting bracket loops must contact the top cover when it is installed.

**12.4.8 General Inspection**

- A. Check the power switch for proper installation and secure hardware. {D2}{B}
- B. Ensure the cardboard (fishpaper) is installed over the power switch and connection. {D7}{B}
- C. Ensure all socket mounted chips are installed properly and firmly seated. {D8}{B}
- D. Ensure the chassis is not bent in the area of the video board. {B9}{B}
- E. Ensure the rear slot brackets are not bent and make good contact with the chassis. {B9}{B}
- F. Check all components, ensure there are no broken leads or damaged components. {B9}{B}
- G. Ensure there are seven card guides attached to the front inside chassis, one for each slot. {D7}{B}

- H. Check the circuit side of the ITI PCBA, ensure there are no shorts or opens in the area of the unused I.C. memory sockets. Note some computers may have all memory sockets used. {C5}{B}

#### 12.4.9 Keyboard Inspection

- A. Check the keyboard for damage and ensure the legs function properly. {B5}{B}
- B. Place the keyboard overlay on the keyboard and ensure that all characters are correct and of the proper size. {B0}{B}
- C. Ensure that all keys are tight and do not pop off when allowed to spring up. {B8}{B}
- D. Connect the keyboard to the computer and check the paint and plastic coloring. Ensure the paint and plastic (Bezels) colors match. {B3}{B}

#### 12.4.10 LED Color Inspection

- A. Check that the FDD LED's are red, monochrome monitor led's are green, color monitor led's are red. {B3}{B}

### 12.5 FUNCTIONAL TEST INSPECTION

This section details the steps of the functional test inspection.

#### 12.5.1 Continuity and Grounding Test

- A. Using an ohmmeter, measure the continuity between the Mother Board ground plane and:
  - 1. The chassis
  - 2. The power supply chassis
  - 3. Ground on the video board
  - 4. The frame on both floppy disk drives
  - 5. The ground springs mounted on the floppy bracket

Ensure there is a 0 Ohm connection between all points.  
{C5}{B}



### 12.5.2 Power Up Sequence

- A. Remove the cardboard inserts from the floppy disk drives.
- B. Connect a monochrome monitor for the alignment test.
- C. Set the Color/Mono switch on the back of the PC to Mono.
- D. From the Mono-monitor, connect both the TTL signal and the Power cable to the rear of the computer.
- E. Connect all test adapters,
  1. Light pen
  2. Mouse
  3. Joy sticks (2 ea)
  4. Parallel Loop Back Plug
  5. Serial Loop Back Plug
- F. Connect the power cord that was included with the unit in the shipping carton to the rear of the computer and to the appropriate AC input power receptacle.
- G. Apply power to the PC.

### 12.5.3 Power Supply Test

- A. Using the voltmeter measure the + 5 Volts for 5 V +/- 5% (0.25 V). Measure the +5 V between ground and the power supply connector red lead nearest the front of the PC. Ensure the voltmeter function is set to measure DC voltage. {C5}{B}

### 12.5.4 Boot Disk # 1

Insert the RED label disk # 1 into the upper floppy disk drive and turn the computer power on. Allow the computer to boot from this disk and verify operation as follows:

- A. The "Phoenix ROM BIOS Ver 2.03a" message will be displayed. {D4}{B}
- B. The "VENDEX Virtual Disk Driver - Version 3.2" message will be displayed. {D4}{B}
- C. The "Bank Switched RAM" message will be displayed. {C5}{B}

D. The following:

"A>echo off"  
 "LOADING THE VENDEX HEAD START ENVIRONMENT, PLEASE WAIT..."  
 message will be displayed. (C5)(B)

E. The HEAD START opening screen will be displayed(C5)(B).

F. Verify that the the time and date displayed at the top of the screen are correct. The time must be New York, NY time to within 1 minute as read from the digital wall clock. (C6)(B)

G. Remove RED label disk # 1 from the upper floppy disk drive.

12.5.5 Alignment Test

This test utilizes a digital alignment test diskette to ensure that the floppy disk drives operate properly. Follow the steps below to perform this test. (C17)(B)

A. Insert the Dysan Interrogater Backup Software diskette in drive "A:", the upper disk drive, and reboot the system by holding down the "Ctrl" and "Alt" buttons then pressing the "Del" button. Verify that the screen displays as shown below:

I N T E R R O G A T O R

By

Dysan CE Division

Copyright 1986 Version 2.05

BACKUP COPY

NOTICE:  
 Please remove Program Disc at this time  
 and press any key to continue ...

- B. Remove the Dysan Interrogator Backup Software diskette from the upper floppy disk drive. Then press the "ENTER" key. The screen should display as shown below:

INTERROGATOR MAIN MENU for the IBM PC, XT

F1 = HELP	F4 = UTILITIES
F2 = AUTO SEQUENCE	F5 = READ / WRITE TEST
F3 = ALIGNMENT TESTS	F6 = SETUP PARAMETERS
WAITING FOR SELECTION ...	

STATUS: Drive = A: Type = 5/40 Track = 9 Side = 0

- C. Press function key "F2" to select the auto sequence menu. The screen should display as shown below:

AUTO SEQUENCE Test for the IBM PC, XT

Dysan DY508-400 Digital Diagnostic Disc Required

Test	Trk	Side 0	Side 1	Range	Delta	Results
CENTERING				± 8	na	
RADIAL				± 8	4	
RADIAL				± 8	4	
RADIAL				± 8	4	
AZIMUTH				± 42	na	
INDEX				0 - 400	200	
INDEX				0 - 400	200	
RPM	na		na	294 - 306	6	na

Enter date (e.g. 9/1/85):

NOTE: Radial and Centering displayed in milli-inches  
Index in microseconds, Azimuth in minutes

STATUS: Drive = A: Type = 5/40 Track = 9 Side = 0

D. Press "ENTER" to skip the date entry function. The screen display should change to:

AUTO SEQUENCE Test for the IBM PC, XT  
 Dysan DY508-400 Digital Diagnostic Disc Required

Test	Trk	Side 0	Side 1	Range	Delta	Results
CENTERING				± 8	na	
RADIAL				± 8	4	
RADIAL				± 8	4	
RADIAL				± 8	4	
AZIMUTH				± 42	na	
INDEX				0 - 400	200	
INDEX				0 - 400	200	
RPM	na		na	294 - 306	6	na

F1 = Exit F2 = Run F3 = Select Drive F4 = Hardcopy

NOTE: Radial and Centering displayed in milli-inches  
 Index in microseconds, Azimuth in minutes

STATUS: Drive = A: Type = 5/40 Track = 0 Side = 0

E. Insert the Dysan DDD diskette into the A: upper floppy disk drive.

F. Press function key "F2" to run the alignment check test for drive A:. When complete the screen will display as shown below: Note that all tests should indicate that they PASSED in the two right most columns of the display.

AUTO SEQUENCE Test for the IBM PC, XT  
 Dysan DY508-400 Digital Diagnostic Disc Required

Test	Trk	Side 0	Side 1	Range	Delta	Results
CENTERING	24	± 8	± 8	± 8	na	Pass Pass
RADIAL	0	-10 +13	-10 +13	± 8	4	Pass Pass
RADIAL	16	-11 +13	-11 +13	± 8	4	Pass Pass
RADIAL	30	-11 +13	-11 +13	± 8	4	Pass Pass
AZIMUTH	34	-42 +42	-42 +42	± 42	na	Pass Pass
INDEX	5	205	302	0 - 400	200	Pass Pass
INDEX	39	211	351	0 - 400	200	Pass Pass
RPM	na	298	na	294 - 306	6	Pass na

F1 = Exit F2 = Run F3 = Select Drive F4 = Hardcopy

NOTE: Radial and Centering displayed in milli-inches  
 Index in microseconds, Azimuth in minutes

STATUS: Drive = A: Type = 5/40 Track = 0 Side = 0

- G. Press function key "F3" to select a different drive. Verify that the screen display changes to that shown below:

AUTO SEQUENCE Test for the IBM PC, XT

Dysan DY508-400 Digital Diagnostic Disc Required

Test	Trk	Side 0	Side 1	Range	Delta	Results
CENTERING				± 8	na	
RADIAL				± 8	4	
RADIAL				± 8	4	
RADIAL				± 8	4	
AZIMUTH				± 42	na	
INDEX				0 - 400	200	
INDEX				0 - 400	200	
RPM	na		na	294 - 306	6	na

SELECT DRIVE TO TEST: F1 = A: F2 = B: F3 = C: F4 = D:

NOTE: Radial and Centering displayed in milli-inches  
Index in microseconds, Azimuth in minutes

STATUS: Drive = A: Type = 5/40 Track = 0 Side = 0

- H. Press function key "F2" to select drive B:. The display should then change to that shown on the following page.

AUTO SEQUENCE Test for the IBM PC, XT

Dysan DY508-400 Digital Diagnostic Disc Required

Test	Trk	Side 0	Side 1	Range	Delta	Results
CENTERING				± 8	na	
RADIAL				± 8	4	
RADIAL				± 8	4	
RADIAL				± 8	4	
AZIMUTH				± 42	na	
INDEX				0 - 400	200	
INDEX				0 - 400	200	
RPM	na		na	294 - 306	6	na

F1 = Exit F2 = Run F3 = Select Drive F4 = Hardcopy

NOTE: Radial and Centering displayed in milli-inches  
Index in microseconds, Azimuth in minutes

STATUS: Drive = B: Type = 5/40 Track = 0 Side = 0

- I. Remove the DDD diskette from the upper floppy disk drive A: and insert it into the lower floppy disk drive B:.
- J. Press function key "F2" to run the alignment check test for drive B:. When complete the screen will display as shown below: Note that all tests should indicate that they PASSED in the two right most columns of the display.

AUTO SEQUENCE Test for the IBM PC, XT  
Dysan DY508-400 Digital Diagnostic Disc Required

Test	Trk	Side 0	Side 1	Range	Delta	Results	
CENTERING	24	± 8	± 8	± 8	na	Pass	Pass
RADIAL	0	-12 +13	-12 +13	± 8	4	Pass	Pass
RADIAL	16	-12 +12	-12 +12	± 8	4	Pass	Pass
RADIAL	30	-12 +12	-13 +12	± 8	4	Pass	Pass
AZIMUTH	34	-42 +42	-42 +42	± 42	na	Pass	Pass
INDEX	5	199	309	0 - 400	200	Pass	Pass
INDEX	39	215	371	0 - 400	200	Pass	Pass
RPM	na	297	na	294 - 306	6	Pass	na

F1 = Exit F2 = Run F3 = Select Drive F4 = Hardcopy

NOTE: Radial and Centering displayed in milli-inches  
Index in microseconds, Azimuth in minutes

STATUS: Drive = B: Type = 5/40 Track = 0 Side = 0

H. Remove the Dysan DDD Diskette from the lower drive B:.

12.5.6 Functional Test Setup

During the functional tests if any displays or operations other than specified are noted, the test is considered a failure. Some of the screen displays included below show a printed character like "=". The actual screen display may have a different character displayed at these points. This detail should not be construed as a failure. {C8}{B}

- A. Exchange display monitors. Turn off the power, disconnect the monochrome monitor signal cable, connect the color monitor signal cable, set the Color/Mono switch on the back of the PC to the Color position then turn power back ON.
- B. Install the VENDEX XT-888 Customer Inspection Software Diskette and reboot the computer system by holding down the "Ctrl" and "Alt" buttons then pressing the "Del" button. {C5}{B}

12.5.7 Light Pen Port Test

- A. The monitor will display :

"First Test is for the Light Pen Port  
Strike a key when ready . . ."

- B. Press the "ENTER" key, the screen will display:

## V E N D E X   L I G H T   P E N   T E S T

Point the Light Pen at the Blue and actuate Switch a number of times. A White Cross should appear near the Pen tip. Do this several times and note if the Cross moves. Test PASS if Cross appears and moves. True Pen to cross position may be adjusted by using the cursor arrow keys.

Press ENTER to EXIT the Light Pen Test.

The lower half of the screen is BLUE.

- C. Touch the Light Pen to the blue section of the screen and activate the pen, a white cross will appear.
- D. Move the Pen and reactivate the Light Pen, the cross will follow the movement of the Light Pen.
- E. Use the arrow keys to readjust the relative position of the cross.
- F. Press the "ENTER" key to exit the Light Pen Test.

#### 12.5.8 Mouse Test

- A. The monitor will display :  
"Second Test is for the Mouse Port  
Strike a key when ready . . . "
- B. Press the "ENTER" key, the screen will display:

"PRESS THE LEFT BUTTON FOR COLOR MONITOR  
PRESS THE RIGHT BUTTON FOR MONO MONITOR"

- C. Press the left button of the mouse to select color monitor, the monitor will display the Microsoft Piano Keyboard.
- D. While pressing the left button on the mouse, move the cursor back and forth over the piano keys, listen for the low octave sounds from the speaker.
- E. While pressing the right button on the mouse, move the cursor back and forth over the piano keys, listen for the high octave sounds from the speaker.
- F. Stop the mouse cursor over any one key, press the mouse keys alternately and verify there is octave change. (Left key low octave, right key high octave.)
- G. Move the mouse cursor to the area marked QUIT and press either of the mouse buttons to QUIT the piano program.

12.5.9 Memory Test

- A. The monitor will display:

"Next Test is for Memory, Parallel & Serial Ports,  
CPU and Disk Drives  
Strike a key when ready . . . "

- B. Press the "ENTER" key and the following display should appear with "1 Memory Test" highlighted:

```

VENDEX HeadStart System Diagnostics Ver 3.0

 1 Memory Test
 2 Parallel Port Test
 3 RS-232 Serial Port Test
 4 Keyboard Test
 5 Video Display Test
 6 Diskette Test
 7 Clock Speed Switch Test

ESC Exit Diagnostic and Return to DOS
    
```

- C. Press "ENTER" again and the memory test select menu will display:

```

VENDEX HeadStart System Diagnostics Ver 3.0

  VENDEX HeadStart System Memory Test Select
    1 Test Main System Memory
    2 Test Bank Switched Memory
    Press ESC to Exit to Main Menu

ESC Exit Diagnostic and Return to DOS
    
```



- D. "1 Test Main System Memory" will be highlighted, press the "ENTER" key to select test main system memory. The monitor will display:

```

VENDEX HeadStart System Diagnostics Ver 3.0
  VENDEX HeadStart System Memory Test Select
    VENDEX HeadStart System Main Memory Test
    Memory Size : 0640 KBytes
    Press ENTER to Test Main Memory
    Press ESC to Exit to Memory Select Menu
  ESC Exit Diagnostic and Return to DOS
    
```

- E. Press "ENTER" to test main memory, the monitor will display as shown below. A screen counter will show the memory test in progress.

```

VENDEX HeadStart System Diagnostics Ver 3.0
  VENDEX HeadStart System Memory Test Select
    VENDEX HeadStart System Main Memory Test
    Memory Size : 0640 KBytes
    Press ENTER to Test Main Memory
    0112
    Press ESC to Exit to Memory Select Menu
  ESC Exit Diagnostic and Return to DOS
    
```

- F. The system will test the memory, at the completion of the test the monitor will display as shown below if the test passed.

```

VENDEX HeadStart System Diagnostics Ver 3.0
  VENDEX HeadStart System Memory Test Select
    VENDEX HeadStart System Main Memory Test
    Memory Size : 0640 KBytes
    Press ENTER to Test Main Memory
    0640 KBytes Memory Test Passed
    Press ESC to Exit to Memory Select Menu
  ESC Exit Diagnostic and Return to DOS
    
```

- G. Press "ESC" to exit the main memory passed screen, the monitor will display:

```

VENDEX HeadStart System Diagnostics Ver 3.0
VENDEX HeadStart System Memory Test Select
  1 Test Main System Memory
  2 Test Bank Switched Memory
Press ESC to Exit to Main Menu

ESC Exit Diagnostic and Return to DOS
    
```

\*\* For PC's with more than 512 KBytes memory the bank switched memory must be tested. All lots of PC's must be checked for this additional memory. If the computer only has 512 KBytes of memory the test sequence should proceed to Step N.

- H. Press the down arrow, "2 Test Bank Switched Memory" line will be highlighted.
- I. Press the "ENTER" key to select the Bank Switched Memory Test.
- J. The monitor will display:

```

VENDEX HeadStart System Diagnostics Ver 3.0
VENDEX HeadStart System Memory Test Select
VENDEX HeadStart System Bank Memory Test
128 KByte Bank Switched RAM Installed
Press ENTER to Test Bank Switched Memory
Press ESC to Exit to Memory Select Menu

ESC Exit Diagnostic and Return to DOS
    
```

- K. Press the "ENTER" key to start the bank switched memory test. The monitor will display as shown below with a counter as the test is done.

```

VENDEX HeadStart System Diagnostics Ver 3.0
VENDEX HeadStart System Memory Test Select
VENDEX HeadStart System Bank Memory Test
128 KByte Bank Switched RAM Installed
Press ENTER to Test Bank Switched Memory
Bank Switch RAM Test in Progress (085K)
Press ESC to Exit to Memory Select Menu
ESC Exit Diagnostic and Return to DOS
    
```

- L. At the completion of the test, if it passed, the monitor will display:

```

VENDEX HeadStart System Diagnostics Ver 3.0
VENDEX HeadStart System Memory Test Select
VENDEX HeadStart System Bank Memory Test
128 KByte Bank Switched RAM Installed
Press ENTER to Test Bank Switched Memory
Bank Switch RAM PASSED Memory Test
Press ESC to Exit to Memory Select Menu
ESC Exit Diagnostic and Return to DOS
    
```

- M. Press the "ESC" key to Exit to the memory select menu. The display will appear as shown in step C of Section 12.5.9.
- N. Press the "ESC" key to exit to the main menu.

12.5.10 Parallel Port Test {C9}{B}

- A. Press the down arrow, "2 Parallel Port Test" line will be highlighted.
- B. Press the "ENTER" key, the monitor will display:

```

VENDEX HeadStart System Diagnostics Ver 3.0
- VENDEX HeadStart System Parallel Port Test
  (Tests System Primary Parallel Port)
  (with Test Plug Installed on LPT1:)

Press ENTER to Test Parallel Printer Port

Press ESC to Exit to Main Menu
    
```

- C. Press the "ENTER" key to start the Parallel Port test.
- D. The line "Parallel Port PASSED Test" will be displayed as shown below if the test was successful.

```

VENDEX HeadStart System Diagnostics Ver 3.0
VENDEX HeadStart System Parallel Port Test
  (Tests System Primary Parallel Port)
  (with Test Plug Installed on LPT1:)

Press ENTER to Test Parallel Printer Port

Parallel Port PASSED Test

Press ESC to Exit to Main Menu
    
```

- E. At the completion of the test, press the "ESC" key to return to the main menu.

12.5.11 RS-232 Serial Port Test {C10}{B}

- A. Press the down arrow "3 RS-232 Serial Port Test" of the main menu will be highlighted.
- B. Press the "ENTER" key, line "1 Test RS-232 Transmit and Receive" is highlighted of the following display:

VENDEX HeadStart System Diagnostics Ver 3.0  1 Memory Test 2 Parallel Port Test 3 RS-232 Serial Port 4 Keyboard Test 5 Video-Display Test 6 Diskette Test 7 Clock Speed Switch  ESC Exit Diagnostic and	VENDEX HeadStart System Serial Port Test (Tests System Primary RS-232C Port) (with Test Plug Installed on COM1:)  COM1: Port Parameters -  1200 Baud No Parity 2 Stop Bit(s) 8 Data Bits  1 Test RS-232C Transmit and Receive 2 Set RS-232C Parameters Press ESC to Exit to Main Menu
---	--

C. Press the "ENTER" key, the monitor will display:

VENDEX HeadStart System Diagnostics Ver 3.0  1 Memory Test 2 3 4 5 6 7  ESC	VENDEX HeadStart System Serial Port Test  VENDEX HeadStart System RS-232C Transmit/Receive Test for COM1: (This Test Requires RS-232 Test Plug) (to be Installed on Primary Serial Port)  ≡ This line of text is sent to test serial port COM1 -123456789ABCDEFGHIJKLMNO PQRSTUVWXYZabcdefghijklmn opqrstuvwxyz..... ≡  Press ENTER to Test RS-232 Serial Port Press ESC to Exit to the Serial Test Menu	Port) COM1:)        Receive
---	--	--

D. Press the "ENTER" key to start the test, the monitor will display the characters moving through the windows.

VENDEX HeadStart System Diagnostics Ver 3.0  1 Memory Test 2 3 4 5 6 7  ESC	VENDEX HeadStart System Serial Port Test  VENDEX HeadStart System RS-232C Transmit/Receive Test for COM1: (This Test Requires RS-232 Test Plug) (to be Installed on Primary Serial Port)  ≡87 9ABCDEFGHIJKLMN0PQRSTUVWXYZ YZabcdefghijklmnpqrstuvw xyz..... This line of text is sent to test serial port COM1-1234567 78≡  Press ENTER to Test RS-232 Serial Port Press ESC to Exit to the Serial Test Menu	Port) COM1:)        Receive
---	--	--

- E. The message "This line .... wxyz..." will shift out the the upper left hand side of the inset box, through the serial port loop then back in the lower right hand side, returning to the original condition, indicating the loop test passed.
- G. The line "Transmit Error" will be displayed if there is a failure. {C5}{B}.
- H. Press "ESC" to exit to the Serial Test Menu.
- I. Press "ESC" to return to the main menu.

12.5.12 Keyboard Test - {C11}{B}

- A. Press the down arrow to select the keyboard test. The line "4 Keyboard Test" of the main menu will be highlighted.
- B. Press the "ENTER" key, the monitor will display:

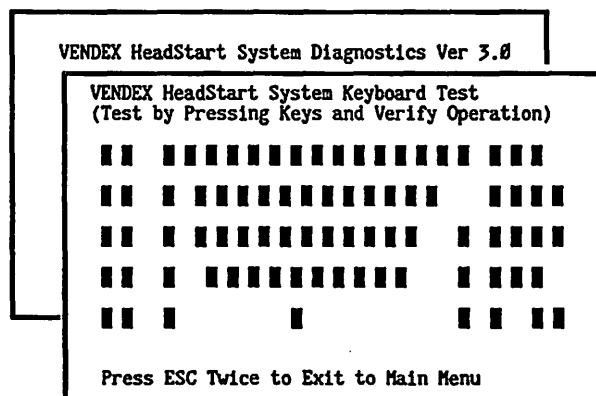

- C. Press all of the keys on the keyboard one at a time, ensure all characters change the correct squares to characters as indicated by the following Figure.

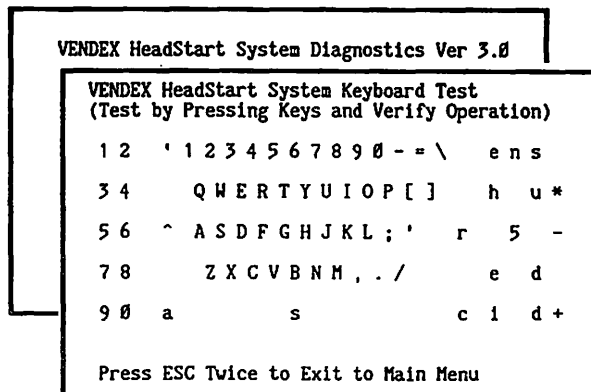

- D. Press the "ESC" key twice to return to the main menu.

12.5.13 Video Display Test {C12}{B}

- A. Press the down arrow to select the video test, the line "5 Video Display Test" of the main menu will be highlited.
- B. Press the "ENTER" key, the video display test screen will be displayed and "1 Attribute Display" will be highlited:

```

VENDEX HeadStart System Diagnostics Ver 3.0
1
2
3
4
5
6
7
ESC
VENDEX HeadStart System Video Display Test
(Color Graphics Adapter is in Use)
1 Attribute Display
2 Character Set Display
Press ESC to Exit to Main Menu
    
```

- C. Press "ENTER" to display the color test display and ensure the lines are as specified Normal, Intensity, Underline, Blink and Reverse video.

```

VENDEX HeadStart System Diagnostics Ver 3.0
1
2
3
4
5
6
7
ESC
VENDEX HeadStart System Video Display Test
VENDEX HeadStart System Display Attributes
Nondisplay nondisplay nondisplay nondisplay
RED
YELLOW
GREEN
CYAN
BLUE
MAGENTA
WHITE
Normal normal normal normal normal normal
Intensity intensity intensity intensity
Reverse reverse reverse reverse reverse
Blink blink blink blink blink blink
Press ESC to Exit to Video Test Menu
    
```

- D. Press "ESC" to return to the video display test screen as shown in step B of Section 12.5.12.
- E. Press the down arrow to select the Character set test, the line "2 Character Set Display" will be highlighted.
- F. Press the "ENTER" key to start the test.
- G. The complete character set will be displayed, ensure the display matches the Figure below.

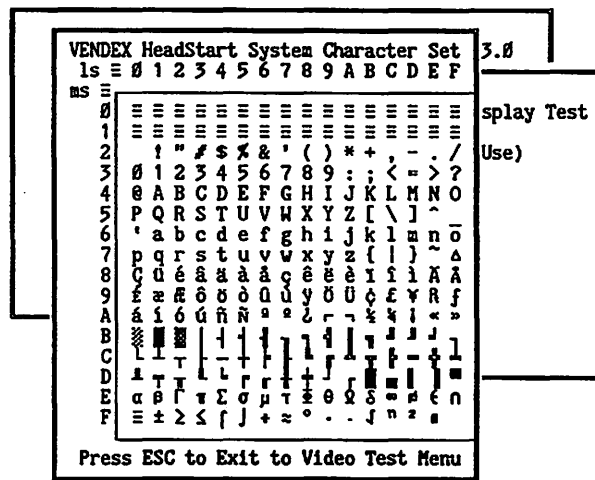

- H. Press "ESC" to return to the video display test screen as shown in step B of Section 12.5.12.
- I. Press the "ESC" key to Exit to the main menu.

12.5.14 Diskette Test {C13}{B}

- A. Press the down arrow to select diskette test, the line "6 Diskette Test" will be highlighted.
- B. Press the "ENTER" key, the drive select screen, as shown in the Figure below will be displayed.



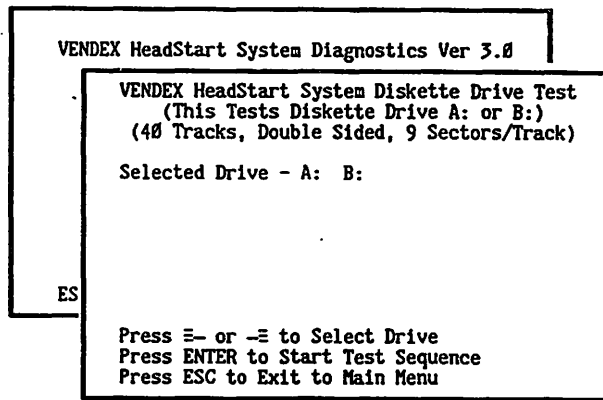

- C. Press the the "ENTER" key to select Drive A: for testing, the message "Press G to Start Test" will be displayed as shown below:

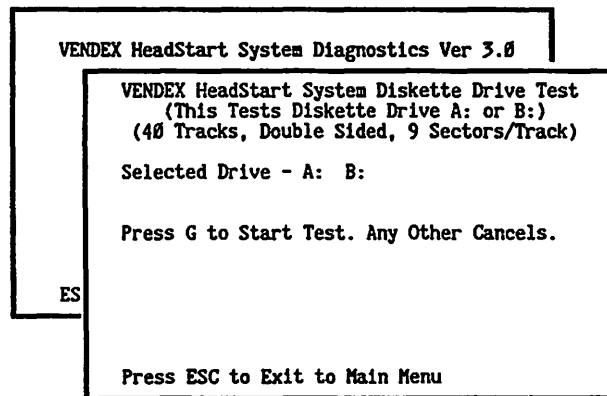

- D. Press the letter "g" to start the test, this test formats, writes, reads, and verifies on tracks 35 through 39.
- E. Ensure there are no errors displayed on the error counter and the "Disk Test PASSED" message is displayed as shown in the figure below.

```

VENDEX HeadStart System Diagnostics Ver 3.0

VENDEX HeadStart System Diskette Drive Test
(This Tests Diskette Drive A: or B:)
(40 Tracks, Double Sided, 9 Sectors/Track)

Selected Drive - A: B:

Testing -
Drive A: Track 39 Side 1 - Verifying
Error Count 000

ES

Disk Test PASSED
Press ENTER to Acknowledge Test Status
Press ESC to Exit to Main Menu
    
```

F. Press the "ENTER" key to acknowledge the test status, the drive select menu as shown in step B of Section 12.5.13 will be displayed.

G. Insert a blank diskette in the lower floppy drive B:. This diskette will be used for the test.

**CAUTION:** Any information on the diskette will be destroyed.

H. Press the Right arrow to select Drive B:, the letter B: will be highlighted.

I. Press the "ENTER" key to display the warning message about the diskette information being destroyed, as shown below:

```

VENDEX HeadStart System Diagnostics Ver 3.0

VENDEX HeadStart System Diskette Drive Test
(This Tests Diskette Drive A: or B:)
(40 Tracks, Double Sided, 9 Sectors/Track)

Selected Drive - A: B:

Insert Scratch Diskette in Floppy Drive then
Press G to Start Test. Any Other Cancels.
Diskette Contents Will be Destroyed !!!!!

ES

Press ESC to Exit to Main Menu
    
```

- J. Press the "g" key to start the test, any other key will cancel the test.
- K. The test will cycle through all 40 tracks Formatting, Writing, Reading and Verifying both heads.
- L. Observe the error counter during the test, verify there are no errors during the test. Refer to display in step E of Section 12.5.13 for disk PASSED message. "Drive B:" will be displayed instead of "Drive A:".

NOTE: Individual isolated errors may be the fault of the diskette. If an error occurs, replace the diskette and rerun the test.

- M. Press the "ESC" key to return to the main menu.

#### 12.5.15 Clock Speed Switch Test {C6}{B}

- A. Press the down arrow, "7 Clock Speed Switch Test" will be highlighted.
- B. Press the "ENTER" key, The clock switching screen will be displayed as shown below:

```
VENDEX HeadStart System Diagnostics Ver 3.0
VENDEX HeadStart System Clock Speed Test
(Tests Clock Switching 4.77 <-> 8.00 MHz)
Press ENTER to Test Processor Clock
Speed Switching
Press ESC to Exit to Main Menu
```

- C. Press the "ENTER" key to start the clock switching test.
- D. During the clock switching speed test the screen will display:

```

VENDEX HeadStart System Diagnostics Ver 3.0
VENDEX HeadStart System Clock Speed Test
(Tests Clock Switching 4.77 <-> 8.00 MHz)

Press ENTER to Test Processor Clock
Speed Switching

Testing Processor Clock Switching . . .
    
```

- E. At the completion of the test, the screen should display the PASSED message as shown below.

```

VENDEX HeadStart System Diagnostics Ver 3.0
VENDEX HeadStart System Clock Speed Test
(Tests Clock Switching 4.77 <-> 8.00 MHz)

Press ENTER to Test Processor Clock
Speed Switching

Processor Clock PASSED Switching Test
    
```

- F. Press the "ESC" key to return to the main menu.
- G. Press the "ESC" key to exit this menu and continue testing.

12.5.16 DMA Controller Test {C18}{B}

- A. The monitor screen will display the message:
- "Next Test is for the DMA Controller  
Strike a key when ready . . . "
- B. Press the "ENTER" key, the screen shown below will be displayed and the test will start.

\*\*\* EXECUTIVE SYSTEMS PERSONAL COMPUTER \*\*\*  
DMA Chip Test - Version 2.0 - 06/8/87  
Samsung Functional System Test Version

This Test will Cycle 32 Times. If the Computer  
Hangs without the Cycle Counter Advancing then  
Reset the System and consider the DMA chip failed.

Performing DMA Controller Chip Test ... Cycle 5

- C. At the completion of the test, the screen will display the following message for a PASSED test:

\*\*\* EXECUTIVE SYSTEMS PERSONAL COMPUTER \*\*\*  
DMA Chip Test - Version 2.0 - 06/8/87  
Samsung Functional System Test Version

This Test will Cycle 32 Times. If the Computer  
Hangs without the Cycle Counter Advancing then  
Reset the System and consider the DMA chip failed.

Performing DMA Controller Chip Test ... Cycle 32

DMA Chip PASSED Test

- D. If the screen below is displayed the Software test diskette is faulty and should be replaced and the test should be rerun.

\*\*\* EXECUTIVE SYSTEMS PERSONAL COMPUTER \*\*\*  
DMA Chip Test - Version 2.0 - 06/8/87  
Samsung Functional System Test Version

Test Track 39 of Diskette Cannot be Formatted  
due to BAD Track 39 or Disk is Write Protected  
DMA Controller Test Canceled.

- E. Press the "ENTER" key when the PASS/FAIL indication has been verified.

12.5.17 Joystick Test {C15}{B}

- A. The screen will display the screen shown below:

Last Test is for the Joy Sticks  
Strike a key when ready . . .

- B. Press the "ENTER" key, the screen will display:

The IBM Personal Computer  
ADVANCED DIAGNOSTICS  
Version X.YY (C)Copyright IBM Corp 1981, 1985  
ROS P/N:  
ROS DATE: 03/05/87

SELECT AN OPTION

- 0 - SYSTEM CHECKOUT
- 1 - FORMAT DISKETTE
- 2 - COPY DISKETTE
- 3 - PREPARE SYSTEM FOR MOVING
- 9 - END DIAGNOSTICS

ENTER THE ACTION DESIRED  
?

- C. Type the number "0" and then the "ENTER" key, selecting System Checkout. The screen will display:

THE INSTALLED DEVICES ARE  
13 - S GAME CONTROL ADAPTER  
IS THE LIST CORRECT (Y/N) ?

- D. Type the character "y", then type the "ENTER" key. The screen will display:

SYSTEM CHECKOUT  
0 - RUN TESTS ONE TIME  
1 - RUN TESTS MULTIPLE TIMES  
2 - LOG UTILITIES  
9 - END SYSTEM CHECKOUT  
ENTER THE ACTION DESIRED  
?

- E. Type the Number "0", then type the "ENTER" key. The screen will display:

13 - S GAME CONTROL ADAPTER

SELECT OPTION NUMBER(S) TO TEST OR  
PRESS ENTER TO SELECT ALL OPTIONS  
?

- F. Type the number "13", then type the "ENTER" key. The screen will display:

WHICH OF THE FOLLOWING IS ATTACHED:  
1 = JOYSTICK  
2 = PADDLE  
3 = NOTHING ATTACHED  
?

- G. Type the number "1", then type the "ENTER" key. The screen will display:

WHICH OF THE FOLLOWING IS ATTACHED:  
1 = JOYSTICK  
2 = PADDLE  
3 = NOTHING ATTACHED  
? 1  
HOW MANY BUTTONS DO YOU HAVE (2/4)?

- H. Type the number "2", then type the "ENTER" key. The screen will display:

BUTTON A RELEASED ***** *A       * *       * *       * *       * *       * *       * *****	BUTTON B RELEASED ***** *B       * *       * *       * *       * *       * *       * *****
---	---

PRESS AND RELEASE ALL BUTTONS,  
EXERCISE ALL JOY STICKS/PADDLES  
AND PRESS ANY KEY WHEN DONE

- I. Press the fire button on the joystick connected to game port #1, observe that the word RELEASED changes to PRESSED above the outline with the letter "A" in it.
- J. Rotate the joystick handle and observe that the letter A inside the outline follows the joystick.
- K. Press the fire button on the joystick connected to game port #2, observe that the word RELEASED changes to PRESSED above the outline with the letter B in it.
- L. Rotate the joystick handle and observe that the letter B inside the outline follows the joystick
- M. Press the "ENTER" key when done to Exit to the menu. An error message is displayed, ignore error message and press the "ENTER" key. The monitor displays:

SYSTEM CHECKOUT

- 0 - RUN TESTS ONE TIME
- 1 - RUN TESTS MULTIPLE TIMES
- 2 - LOG UTILITIES
- 9 - END SYSTEM CHECKOUT

ENTER THE ACTION DESIRED  
?

- N. Press "9" for option to END SYSTEM CHECKOUT, and press the "ENTER" key. The monitor displays:

- SELECT AN OPTION
- 0 - SYSTEM CHECKOUT
  - 1 - FORMAT DISKETTE
  - 2 - COPY DISKETTE
  - 3 - PREPARE SYSTEM FOR MOVING
  - 9 - END DIAGNOSTICS
- ENTER THE ACTION DESIRED  
?

- O. Select END DIAGNOSTICS by typing the number "9" and pressing the "ENTER" key. The monitor will display the following:



SELECT AN OPTION  
0 - SYSTEM CHECKOUT  
1 - FORMAT DISKETTE  
2 - COPY DISKETTE  
3 - PREPARE SYSTEM FOR MOVING  
9 - END DIAGNOSTICS  
ENTER THE ACTION DESIRED  
? 9  
INSERT SYSTEM DISKETTE IN DRIVE A  
AND PRESS ENTER  
?

#### 12.6 FINAL SYSTEM BUTON UP

Turn the power off then install the top cover and the five (5) screws securing it. Check the screw heads, ensure the paint was not damaged by the removal and installation process.

12.7 SOFTWARE INSPECTION

The six software diskettes that are included with the VENDEX HeadStart system are inspected to ensure that they are the right diskettes with the right contents. The testing of these diskettes is done on a hard disk based system in the inspection area that contains comparison images of the master VENDEX software diskettes. The customer audit inspection manager controls the setup of this system using batch files provided by ESI.

- A. Verify that there are six diskettes with the sample unit. They should be numbered 1 to 6 with the following label colors and software contents titles.

Disk Number	Label Color	Software Title
DISK 1	RED	VENDEX HEADSTART
DISK 2	BLUE	UTILITIES
DISK 3	GREY	ATI TRAINER
DISK 4	BROWN	EXECUTIVE WRITER
DISK 5	GREEN	EXECUTIVE FILER
DISK 6	ORANGE	MYCALC

- B. The media contents test is started by powering up the hard disk system. It will boot up to the "C>" prompt.
- C. In response to the C> prompt enter the string "INSPECT" from the keyboard followed by pressing the "ENTER" key.

- D. The screen will display the text as shown below:

```
"VENDEX HeadStart Diskette QA Inspection Procedure

Please insert DISK 1 (red) VENDEX HEADSTART disk
                                                    into Drive A:
Strike a key when ready . . ."
```

- E. Insert the # 1 diskette into the upper floppy drive A: and press the "ENTER" key. The diskette will be tested and if it FAILS the screen will display text like:

"Inspection FAILED  
Diskette Number 1 (red) failed."

If the Diskette fails it is considered a functional system failure. {C19}{B}

- F. If the Diskette passes the screen will display the text:

"Please insert DISK 2 (blue) UTILITIES and GWBasic disk  
into Drive A:

Strike a key when ready . . ."

- G. Insert the # 2 diskette into the upper floppy drive A:  
and press the "ENTER" key.

- H. If the diskette # 2 fails please reference step E above  
to note failure criteria. If it passed the screen will  
display the text:

"Please insert DISK 3 (grey) ATI TRAINER disk into  
Drive A:

Strike a key when ready . . ."

- I. Insert the # 3 diskette into the upper floppy drive A:  
and press the "ENTER" key.

- J. If the diskette # 3 fails please reference step E above  
to note failure criteria. If it passed the screen will  
display the text:

"Please insert DISK 4 (brown) EXECUTIVE WRITER disk  
into Drive A:

Strike a key when ready . . ."

- K. Insert the # 4 diskette into the upper floppy drive A:  
and press the "ENTER" key.

- L. If the diskette # 4 fails please reference step E above  
to note failure criteria. If it passed the screen will  
display the text:

"Please insert DISK 5 (green) EXECUTIVE FILER disk  
into Drive A:

Strike a key when ready . . ."

- M. Insert the # 5 diskette into the upper floppy drive A:  
and press the "ENTER" key.

- N. If the diskette # 5 fails please reference step E above  
to note failure criteria. If it passed the screen will  
display the text:

"Please insert DISK 6 (orange) MYCALC disk into Drive A:  
Strike a key when ready . . ."

- O. Insert the # 6 diskette into the upper floppy drive A:  
and press the "ENTER" key.
- P. If the diskette # 6 fails please reference step E above  
to note failure criteria. If it passed the screen will  
display the text:  
  
"Diskettes PASSED"
- Q. Remove the # 6 Diskette from the top floppy drive A:.
- R. Press the "ENTER" key to restart the software diskette  
inspection procedure at step D above. This allows  
immediate inspection of another set of diskettes. To  
stop the diskette inspection procedure enter CTL-C,  
(hold down "CTL" key and press the "C" key). This will  
return the hard disk system to the C> prompt.

### 13 MONOCHROME MONITOR INSPECTION PROCEDURE

This procedure is provided for the testing and inspection of the VENDEX M-888-M monochrome monitor.

This procedure defines the test and inspection requirements, criteria for acceptance and rejection both visual and functional, for both of the monitor products.

#### 13.1 RELATED DOCUMENTS

The following documents are relevant information to this inspection procedure. Excerpts from items A and B are included as attachments to this document.

- A. NSTA Specification (National Safe Transit Authority)
- B. MIL-STD-105D

#### 13.2 TEST EQUIPMENT

The following test equipment is necessary to perform the test and inspection of the VENDEX monitors. In all cases items equivalent in function and quality to those listed may be utilized for the test.

- A. Monochrome monitor test program diskette
- B. Minolta TV analyzer Model TV-2130, TV analyzer II
- C. VENDEX Turbo XT-88 Computer
- D. Monochrome Monitor Display template
- E. Color Monitor Display template

#### 13.3 VISUAL INSPECTION

Perform visual inspection of the monitor by looking at all items listed below. Apply the steps for color or monochrome tubes as appropriate.

- A. Check that all cables are clean.
- B. Make sure all hardware is installed and correct.
- C. Check the cabinet for cleanliness.
- D. Ensure there are no scratches.

- E. Ensure the bezel lettering and coating are clean and not damaged or over sprayed.
- F. Ensure the monitor tilts and swivels freely, does not bind, and is secure and can hold the monitor in place.

#### 13.4 LABELS

Check the monoitor for the proper labels.

- A. Serial Number tag
  - on the bottom of the monochrome monitor
  - on back of the color monitor
- B. VENDEX label on the back
- C. Agency approval labels on back (UL/CSA/FCC)

#### 13.5 PACKAGING

Check the packaging to make sure the unit is in a shippable condition and then verify the following items:

- A. Correct VENDEX box
- B. Monitor is packed in a poly bag
- C. Power cord is in box attached to the monitor
- D. Signal cable is in the box attached to the monitor
- D. The box contains the operator instruction booklets and other documentation

#### 13.6 TEST INSPECTION

Attach the monitor to the VENDEX PC. Ensure that the COLOR/MONO switch on the back of the computer is set appropriately for the type of monitor being tested. Both the signal cable and monitor power cable are to be attached to the VENDEX computer. When attaching the monitor be careful not to bump, move, or turn the brightness and/or contrast controls from their initial positions.

The test is started by inserting the proper software test diskette into the VENDEX PC and powering up the computer and loading the software. Once the test program is loaded all test parameters are defined by function keys F1 through F6, do not use any other keys. Use the function key to start a test as defined at the beginning of each test (F1). Make sure to use the

proper software diskette for the type of monitor being tested.

After the monitor was powered up ensure that the screen raster is visible. If it is not visible the monitor shall be deemed a functional failure, even if it is due to mis-adjustments of the brightness and/or contrast controls.

#### 13.6.1 Function Test 1

- A. Depress function key "F1".
- B. Using the TV analyzer adjust the intensity to 10 FT/L +/- 1.0 FT/L.
- C. Place the Display Template over the front of the screen. Make sure to use the proper type for the type of monitor being tested.
- D. Verify the following physical characteristics of the monitor.
  1. PICTURE SIZE H = 204 +/- 2.5 mm  
V = 137 +/- 2.5 mm  
Picture fits in the dimensions of the template.
  2. LINEARITY 10 % ( H & V )
  3. GEOMETRIC DISTORTION
  4. TILT : 1
  5. JITTER does not appear at 50cm distance
  6. RESOLUTION visual check
  7. Ensure the screen is green phosphor in the Case of monochrome monitors.
  8. Verify that the power indicator of the monochrome monitor is green (or that the color monitor indicator is red).

#### 13.6.2 Function Test 2 (Focus)

- A. Depress function key "F2"
- B. Decrease the intensity until nine small squares are visible
- C. Check the focus of each point. Two or less points out of focus PASS while three or more points out of focus FAIL.

**13.6.3 Function Test 3 (High Resolution)**

- A. Depress function key "F3"
- B. Set the brightness to maximum
- C. Vary the contrast between minimum and maximum, ensure the center one third of the screen goes blank (0 to 7 FT/L).

**13.6.4 Function Test 4 (Low Intensity)**

- A. Depress function key "F4"
- B. Ensure the center of the screen is blank (0 to 7 FT/L)
- C. Verify that the contrast control has no effect.

**13.6.5 Function Test 5 (High Voltage Resolution)**

- A. Depress function key "F5"
- B. Ensure that the screen alternates between bright on and off.

**13.6.6 Function Test 6 (Linearity and Focus)**

- A. Depress function key "F6"
- B. Ensure that all characters are in focus
- C. Check that the raster is rectangular
- D. Make sure that all lines of characters are straight and vertical.

**13.6.7 Picture Brightness**

- A. Depress function key "F3"
- B. Set the brightness control to maximum
- C. Set the contrast control to maximum
- D. Measure the picture intensity. The TV analyzer should indicate between 40 and 50 FT/L.



**13.6.8 Tap Test**

- A. Decrease the brightness control to mid range
- B. Decrease the contrast control to mid range
  
- C. Tap the sides and top of the monitor case and observe the screen for any of the following functional failures:
  - Loss of synchronization
  - Picture jitter
  - Picture outline waveness
  - Distortion in the picture

**13.6.9 Test Completion**

Remove power from the monitor and disconnect it from the VENDEX computer.

## 14 COLOR MONITOR INSPECTION PROCEDURE

This procedure is provided for the testing and inspection of the VENDEX M-888-C color monitor.

This procedure defines the test and inspection requirements, criteria for acceptance and rejection both visual and functional, for the monochrome monitor products.

### 14.1 RELATED DOCUMENTS

The following documents are relevant information to this inspection procedure. Excerpts from items A and B are included as attachments to this document.

- A. NSTA Specification (National Safe Transit Authority)
- B. MIL-STD-105D

### 14.2 TEST EQUIPMENT

The following test equipment is necessary to perform the test and inspection of the VENDEX monitors. In all cases items equivalent in function and quality to those listed may be utilized for the test.

- A. Color monitor test program diskette
- B. Minolta TV analyzer Model TV-2130, TV analyzer II
- C. VENDEX Turbo XT-88 Computer
- D. Color Monitor Display template

### 14.3 VISUAL INSPECTION

Perform visual inspection of the monitor by looking at all items listed below. Apply the steps for color or monochrome tubes as appropriate.

- A. Check that all cables are clean.
- B. Make sure all hardware is installed and correct.
- C. Check the cabinet for cleanliness.
- D. Ensure there are no scratches.

- E. Ensure the bezel lettering and coating are clean and not damaged or over sprayed.
- F. Ensure the monitor tilts and swivels freely, does not bind, and is secure and can hold the monitor in place.

#### 14.4 LABELS

Check the monoitor for the proper labels.

- A. Serial Number tag
  - on the bottom of the monochrome monitor
  - on back of the color monitor
- B. VENDEX label on the back
- C. Agency approval labels on back (UL/CSA/FCC)

#### 14.5 PACKAGING

Check the packaging to make sure the unit is in a shippable condition and then verify the following items:

- A. Correct VENDEX box
- B. Monitor is packed in a poly bag
- C. Power cord is in box attached to the monitor
- D. Signal cable is in the box attached to the monitor
- D. The box contains the operator instruction booklets and other documentation
- E. The stand is packed in a poly bag

#### 14.6 TEST INSPECTION

Attach the monitor to the VENDEX PC. Ensure that the COLOR/MONO switch on the back of the computer is set appropriately for the type of monitor being tested. Both the signal cable and monitor power cable are to be attached to the VENDEX computer. When attaching the monitor be careful not to bump, move, or turn the brightness and/or contrast controls from their initial positions.

The test is started by inserting the proper software test diskette into the VENDEX PC and powering up the computer and loading the software. Once the test program is loaded all test

parameters are defined by function keys F1 through F6 and the ALT and SHIFT keys, do not use any other keys. Use the function key to start a test as defined at the beginning of each test (F1). Make sure to use the proper software diskette for the type of monitor being tested.

After the monitor was powered up ensure that the screen raster is visible. If it is not visible the monitor shall be deemed a functional failure, even if it is due to mis-adjustments of the brightness and/or contrast controls.

#### 14.6.1 RED Color and Purity Test

- A. Depress the "SHIFT" key and type the "F1" key, then release both keys.
- B. The Color Monitor will display only the color RED, and any missing dot will be within the specification.

#### 14.6.2 GREEN Color and Purity Test

- A. Depress the "SHIFT" key and type the "F2" key, then release both keys.
- B. The monitor will display only the color GREEN, and any missing dot will be within the specification.

#### 14.6.3 BLUE Color and Purity Test

- A. Depress the "SHIFT" key and type the "F3" key, then release both keys.
- B. The monitor will display only the color BLUE, and any missing dot will be within the specification.

#### 14.6.4 High Voltage Regulation

- A. Depress the "SHIFT" key and type the "F4" key, then release both keys.
- B. Verify the screen alternates between black and white.
- C. Verify the outside lines do move or change positions by more than 2 mm.

#### 14.6.5 Focus Test

- A. Depress the "ALT" key and type the "F3" key, the screen will be filled with RED squares and "@"'s.
- B. Check the focus of the dots and characters.

**14.6.6 Color and Contrast Test (16 color)**

- A. Depress the "SHIFT" key and type the "F6" key, then release both keys.
- B. Verify the 16 colors.
- C. Decrease the contrast to minimum, the upper set of color blocks will disappear.

**14.6.7 Jitter Test**

- A. Depress the "SHIFT" key and type the "F8" key, then release both keys.
- B. There will be no Jitter when the screen is observed from 50 cm (19.68 in.)
- C. Visually check along the edges for "RIPPLE", ensure there is no interference.

**14.6.8 Picture Size**

- A. Depress the "ALT" key and type the "F3" key, then release both keys.
- B. Using the Color Monitor Template measure the picture size:

Vert. 244mm(9.606in) + or - 4mm(.157in)  
Horiz. 172mm(6.77 in) + or - 4mm(.157in)  
Linearity Horiz. 10%  
Linearity Vert. 7%  
Tilt + or - 2mm(.0987in)

- C. On the back of the unit, set the Color/Mono switch to Mono, the screen will change to green only, simulating a green screen monochrome monitor.
- D. Return the Color/Mono switch to the Color position.

**14.6.9 Misconvergence**

The Misconvergence for the center of the screen is allowed to be .5mm while the outer edges of the screen are allowed to have .8mm Misconvergence. This specification applies to all two color combinations. Look for color separation between the two colors.

- A. Depress the "ALT" key and type the "F6" key, then release both keys.
- B. The screen will be Red and Green, check for

misconvergence.

- C. Depress the "ALT" key and type the "F7" key, then release both keys.
- D. The screen will be Green and Blue, check for misconvergence.
- E. Depress function key "F3".
- F. The screen will be Red and Blue, check for misconvergence.

14.6.10 Brightness

- A. Depress the function key "F4".
- B. Adjust the Contrast and Brightness for max and ensure the TV analyzer measures a minimum of 30fl.

14.6.11 White Balance

- A. Depress the the function key "F5".
- B. Adjust the Brightness and Contrast to 20fl on the TV analyzer. Measure the "X" and "Y":

$$X = 0.281 + \text{or} - .03 (.251-.311)$$

$$Y = 0.311 + \text{or} - .03 (.281-.341)$$

--- End of Document ---

VENDEX COMPUTER INSPECTION TEST PROCEDURE

CHECK LIST

12.4 VISUAL INSPECTION

- 12.4.1 Packaging Inspection \_\_\_\_\_
- 12.4.2 Top Cover Inspection \_\_\_\_\_
- 12.4.3 Bottom Inspection \_\_\_\_\_
- 12.4.4 PCBA Inspection \_\_\_\_\_
- 12.4.5 Power Supply Inspection \_\_\_\_\_
- 12.4.6 Wiring and Cable Inspection \_\_\_\_\_
- 12.4.7 Back and Sides Inspection \_\_\_\_\_
- 12.4.8 General Inspection \_\_\_\_\_
- 12.4.9 Keyboard Inspection \_\_\_\_\_
- 12.4.10 LED Color Inspection \_\_\_\_\_

12.5 FUNCTIONAL TEST INSPECTION

- 12.5.1 Continuity and Grounding Test \_\_\_\_\_
- 12.5.2 Power Up Sequence \_\_\_\_\_
- 12.5.3 Power Supply Test \_\_\_\_\_
- 12.5.4 Boot Disk # 1 \_\_\_\_\_
- 12.5.5 Alignment Test \_\_\_\_\_
- 12.5.6 Functional Test Setup \_\_\_\_\_
- 12.5.7 Light Pen Test \_\_\_\_\_
- 12.5.8 Mouse Test \_\_\_\_\_
- 12.5.9 Memory Test \_\_\_\_\_
- 12.5.10 Parallel Port Test \_\_\_\_\_

12.5.11	RS-232 Serial Port Test	_____
12.5.12	Keyboard Test	_____
12.5.13	Video Display Test	_____
12.5.14	Diskette Test	_____
12.5.15	Clock Speed Switch Test	_____
12.5.16	DMA Controller Test	_____
12.5.17	Joystick Test	_____
12.6	FINAL SYSTEM BUTTON UP	_____
12.7	SOFTWARE INSPECTION	_____



MONOCHROME MONITOR INSPECTION PROCEDURE

CHECK LIST

- 13.1 RELATED DOCUMENTS \_\_\_\_\_
- 13.2 TEST EQUIPMENT \_\_\_\_\_
- 13.3 VISUAL INSPECTION \_\_\_\_\_
- 13.4 LABELS \_\_\_\_\_
- 13.5 PACKAGING \_\_\_\_\_
- 13.6 TEST INSPECTION \_\_\_\_\_
- 13.6.1 Function Test 1 \_\_\_\_\_
- 13.6.2 Function Test 2 (Focus) \_\_\_\_\_
- 13.6.3 Function Test 3 (High Resolution) \_\_\_\_\_
- 13.6.4 Function Test 4 (Low Intensity) \_\_\_\_\_
- 13.6.5 Function Test 5 (High Voltage Resolution) \_\_\_\_\_
- 13.6.6 Function Test 6 (Linearity and Focus) \_\_\_\_\_
- 13.6.7 Picture Brightness \_\_\_\_\_
- 13.6.8 Tap Test \_\_\_\_\_
- 13.6.9 Test Completion \_\_\_\_\_

**COLOR MONITOR INSPECTION PROCEDURE**

**CHECK LIST**

- 14.1 RELATED DOCUMENTS \_\_\_\_\_
- 14.2 TEST EQUIPMENT \_\_\_\_\_
- 14.3 VISUAL INSPECTION \_\_\_\_\_
- 14.4 LABELS \_\_\_\_\_
- 14.5 PACKAGING \_\_\_\_\_
- 14.6 TEST INSPECTION \_\_\_\_\_
- 14.6.1 RED COLOR AND PURITY TEST \_\_\_\_\_
- 14.6.2 GREEN COLOR AND PURITY TEST \_\_\_\_\_
- 14.6.3 BLUE COLOR AND PURITY TEST \_\_\_\_\_
- 14.6.4 HIGH VOLTAGE REGULATION \_\_\_\_\_
- 14.6.5 FOCUS TEST \_\_\_\_\_
- 14.6.6 COLOR AND CONTRAST (16 COLOR) \_\_\_\_\_
- 14.6.7 JITTER TEST \_\_\_\_\_
- 14.6.8 PICTURE SIZE \_\_\_\_\_
- 14.6.9 MISCONVERGENCE \_\_\_\_\_
- 14.6.10 BRIGHTNESS \_\_\_\_\_
- 14.6.11 WHITE BALANCE \_\_\_\_\_

## Chapter 3. Problem Isolation Inspection

### Introduction

This chapter provides information that will help you identify a component that is causing a problem. Each of the components of the system should always be inspected before replacing subassemblies. For this inspection, the cover must be removed.

#### NOTE:

For an internal view of the system unit and subassembly identification, refer to Chapter 6 of this manual.

### PCBA Inspection

1. Ensure that all PCBA's are installed properly and that all hardware is secure.
2. Ensure that the ITI Video PCBA is installed in the J1 slot.
3. Check the jumpers on the ITI Video board for proper position. The proper positions are listed below:

#### Video Board Jumper Switch Settings

JP1	Up
JP2	Down
JP3	Down
JP4	Down
JP5	Up
JP6	Up
JP7	Up
JP10	Up

4. Check to see that the game port bracket (with the two connectors) covers the J2 rear panel slot.
5. Verify that the CPU PCBA is installed in the J3 slot. Make sure that the speaker and keyboard connector cables are attached.
6. Check the CPU board DIP switch settings and make sure that they are set according to the table below.

#### CPU Board DIP Switch Settings

1	Off
2	On
3	Off
4	Off
5	On
6	On
7	Off
8	On

7. Ensure that the small label on the switch block specifies the switch numbers as 1 through 8 with 1 being toward the front of the computer.
8. Ensure that the PCBA's are fully seated.

## **Problem Isolation Inspection**

---

9. Check to see that all components are installed properly with proper lead length.
10. Make sure that the crystals are attached to the PCBA's with adhesive or tape, and that the larger capacitors are securely attached and undamaged.
11. Check the J1 to J7 connectors mounted on the mother board for bent or missing pins. Be sure that there is no foreign material trapped in the connectors.

## **Power Supply Inspection**

1. Ensure that the power supply is mounted properly and that all hardware is secure. Check the power cable to ensure that it is routed properly and that the connector is tight.
2. Check all wire crimps.
3. Ensure that all cables and wires are routed properly and that the connectors are seated properly.

## **General Inspection**

1. Check the power switch to be sure that it is properly installed and that the hardware is secure.
2. Ensure that the cardboard (fishpaper) is installed over the power switch and connection.
3. Ensure that all socket mounted chips are installed properly and that they are firmly seated.
4. Ensure that the chassis is not bent in the area of the video board.
5. Ensure that the rear slot brackets are not bent and that they make good contact with the chassis.
6. Check all components to ensure that there are no broken leads or damaged parts.
7. Ensure that there are seven card guides attached to the front inside chassis. There should be one for each slot.
8. Check the circuit side of the ITI PCBA to ensure that there are no shorts or opens in the area of the unused I.C. memory sockets. Note that all memory sockets may be used in some computers.

## **Keyboard Inspection**

1. Check the keyboard for damage and ensure that the legs function properly.
2. Place the keyboard overlay on the keyboard and ensure that all characters are correct and of the proper size.
3. Ensure that all keys are tight and that they do not pop off when allowed to spring up.
4. Using an ohmmeter, measure the continuity between the Mother Board ground plain and:
  - The chassis
  - The power supply chassis
  - The ground on the video board
  - The frame on both floppy disk drives
  - The ground springs mounted on the floppy bracket

Ensure that there is a 0 Ohm connection between all points.

If a problem still exists after the Problem Isolation Inspection is completed, proceed to Chapter 5.

## Chapter 4. Problem Isolation Procedure

### Introduction

This chapter provides information and instructions for isolating problems with the Turbo-888-XT computer system. It also provides a parts list showing the various components that may need to be replaced if a problem cannot be rectified by another means.

Following is a list of specific instructions for checking out the various components of the computer system.

### Power-On Self Test

When you first turn on the computer, the system will begin a Power-On Self Test and the following message will be displayed:

```
Phoenix ROM BIOS Ver 2.03C
Copyright 1984, 1985 Phoenix Software Associates Ltd.
All Rights Reserved
```

```
RAM Test 256K
```

Check to see that the amount of memory displayed by the Power-On Self Test is the same as the actual memory installed in the system.

### Power-On Self Test Errors

The following is a list of problems you may encounter during the Power-On Self Test:

- A blank display
- An incorrect audio response
- An error message like:

#### BIOS ROM Checksum Error Message

```
Rom bad checksum = XX (value of checksum)
```

#### Timer Counter 2 Error Message

```
Timer chip counter 2 failed
```

#### Keyboard Error Message

```
No scan code from keyboard  
Stuck key scancode = XXh (value of scancode)
```

If a Power-On Self Test error occurs, shut the system off and check all external cables and power connections. Turn the system unit on and allow the test to run again. If the problem still exists remove the cover from the system unit and check for improper board seating, bad internal cabling or improper switch settings.

## Chapter 4

---

### Problem Solving Questions

Did the basic screen appear on your monitor?

**Yes:** Wait a moment until the end of the memory test.

**No:** If the Boot Up screen is not displayed, check to see if the power on the monitor is turned ON. Turn the brightness and contrast knobs on the monitor fully clock wise until the basic screen message appears. Then, adjust the brightness and contrast until the message on the screen is stable and readable.

If the monitor does not display the basic screen but you hear 6 beeps (one is long, the others are short), check and reset the DIP switch settings on the video display and CPU boards.

Check the power cord and the video connector to be sure that they are plugged in properly. If they are, replace the cord and connector and test the system again.

If the basic screen still does not appear on the monitor, replace the CPU board.

#### NOTE:

If you are unable to power on, complete a Power-On Self Test, or see the basic screen display, refer to Chapters 5 and 6.

After the basic screen appears on the monitor, the system unit will check the ROM BIOS, the keyboard, and each of the ports, before it checks the system memory.

If you have an unmatched ROM BIOS, the following error message will be displayed:

Phoenix ROM BIOS Ver 2.03C  
Copyright 1984, 1985 Phoenix Software Associates Ltd.  
All Rights Reserved

ROM bad checksum = XX (the value of checksum)

If the above message appeared on the screen, replace the system ROM and retest.

After the basic screen appears on the monitor, the system unit will start the memory test. The memory test range is from 256Kb (in the standard system) to 512Kb or 640Kb (optional).

### Error Messages and Solutions

This section describes each of the error messages you may encounter and provides a solution to the problem.

**Message:** *Bad RAM at XXXXX = xxH expected = ooH*

(XXXXX = ADDRESS)  
(xxH = FALSE DATA)  
(ooH = TRUE DATA)

**Solution:** If this error message was generated, you should replace the memory chips on the CPU board and/or the Mother Board. The test point and waveform are described at the end of this section.

**Message:** *Unaccepted HW Interrupt at XXXX:XXXX  
Type (R)eboot, other key to continue*

(XXXX:XXXX = ADDRESS)

**Solution:** If this error was generated, the data bus or address bus was abnormal. You must replace the CPU board.

**Message:** *Memory Parity NMI interrupt CS:IP = XXXX:XXXX*

(XXXX:XXXX = ADDRESS)

**Solution:** This message represents a mistake in the memory control signal for the memory read and write test. Replace the CPU board, but only as a last solution.

**Message:** *I/O Board NMI Interrupt CS:IP = XXXX:XXXX*

**Solution:** Generally this message explains a fault in the memory expansion board. You must replace the memory expansion board.

**Message:** *No Scan Code From Keyboard Error*

**Solution:** Replace the keyboard connector.

**Message:** *Stuck Scan Code = XXh*

**Solution:** Replace the keyboard.

## Chapter 4

---

### CPU Tests

The minimum system required for testing the CPU board is composed of the mother board, the display adapter, the power supply and a diskette drive. The CPU board can have problems in any of the following three areas:

- Check sum errors in the ROM BIOS
- Errors of the 256Kb basic memory
- Interrupt or NMI errors.

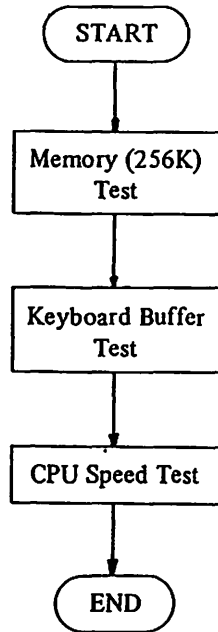

Figure 4-1. CPU Board Test Flow Chart

### CPU Board Specifications

- There are 62 card edge tabs inserted into the slots on the mother board.
- There are three pin headers and a DIP switch. The DIP switch provides the system software with information about the installed options. J1 and J2 decide the size of the BIOS ROM. J3 decides the port address of the CPU clock switching circuit.
- The processor operates at 4.77 MHz which is derived from a 14.31818MHz crystal and at 8MHz derived from a 24 MHz crystal. The speed can be selected by pressing the Ctrl and Alt keys and then pressing "+" or "-" depending on whether you want to increase or decrease the speed.
- The OSC is derived from the 14.31818MHz crystal.
- The DMA clock and PCLK are derived from a 4.7727266MHz crystal.
- The DMA clock is divided 2 for the PCLK.
- There are 256KB DRAM's on the CPU board. The ROM BIOS recognizes the memory size by checking memory space.
- The keyboard and speaker connectors are located on the CPU board.
- The PAL (U20) makes AEN, RAS and CAS signals by using the address and memory read and write signal. The memory on the CPU board used to the RAS and the CAS.



(insert Samsung drawing)

**Figure 4-2. CPU Figure Parts Arrangement Plan**

(insert Samsung drawing

**Figure 4-3. CPU Board**

# Problem Isolation Procedure

## CPU Switch Settings

This section shows the 8-position DIP switch and the meaning of the various switches.

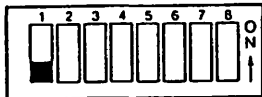

Position	Function
1	Normal operation OFF
2	Used for Math Coprocessor
3-4	Amount of memory on the system board
6	Type of monitor being used
7-8	Number of 5 1/4 inch disk drives attached

## Math Coprocessor Switch Settings - position 2

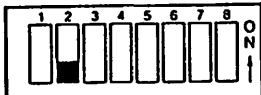

Math Coprocessor installed

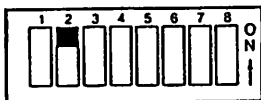

Math Coprocessor not installed

## CPU System Board Memory Switch Settings - positions 3 and 4

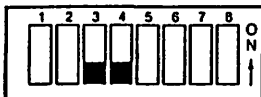

These represent the only valid settings for the VENDEX Headstart System.

## Monitor Type Switch Settings - positions 5 and 6

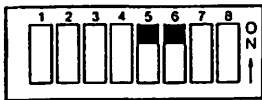

BIOS autoselect (default). This is the standard position and allows you to use either color or monochrome monitors along with the VENDEX environment and software packages. You can select your own monitor type from the video toggle switch without opening your unit. Switch the toggle up for color and down for monochrome.

## 5 1/4 Inch Diskette Drive Switch Settings - positions 7 and 8

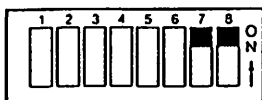

One Drive

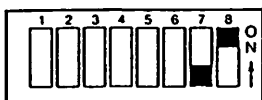

Two Drives



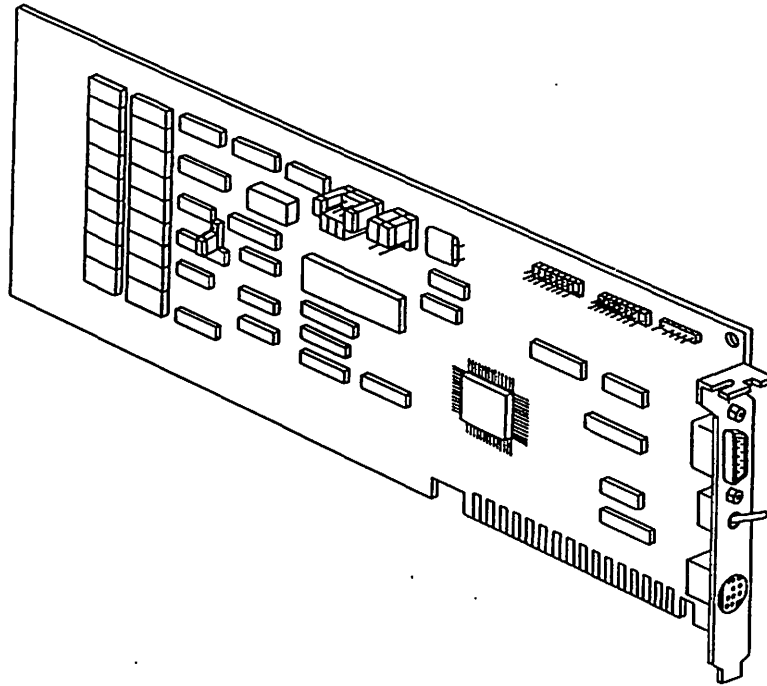

Video Display Adapter View 2

## Chapter 4

---

### Checking Out the Video Display

If your display is blank or you hear three long and short beeps:

1. Set the system unit power switch to OFF.
2. Remove the cover from the system unit.
3. Set the switch on the CPU board according to the settings shown in the previous section.
5. Replace the system unit cover and the video connector.

If the display is distorted or the characters are the wrong size:

1. Turn the monitor ON.
2. Turn the brightness and contrast controls fully clockwise.
3. Turn the vertical size control fully counter clockwise. A black area should appear across the top and bottom of the screen.
4. Turn the vertical hold control clockwise as far as it will go, then turn it counter clockwise until the screen stops rolling and is stable.
5. Turn the vertical size control clockwise until the black area at the top and bottom of the screen just disappears. If one of the black areas disappears before the other, continue to turn the control until the second black area is gone.
6. Adjust the brightness and contrast controls for eye comfort.

## Power Supply

Set the power switch on the system unit to ON. Did the Power-On screen display appear?

**Yes:** The end of the power supply test.

**No:** Check the input voltage selection switch.  
(European type: 230Vac)  
(American type: 115Vac)

If the cooling fan does not operate in your system, you may have a failing power cable or power connectors.

Set the power switch on the system unit to OFF.

Remove the power connector from the mother board and diskette drives.

Measure the voltage of each terminal from the power connectors. (Set the power switch on the power supply to ON.)

You may have a failing power supply. Change your power supply.

**Table 4-1. Power Connector Pinouts**

Pin	Description
1	Not Used
2	Not Used
3	+12 Vdc
4	-12 Vdc
5	GND
6	GND
7	GND
8	GND
9	-5 Vdc
10	+5 Vdc
11	+5 Vdc
12	+5 Vdc

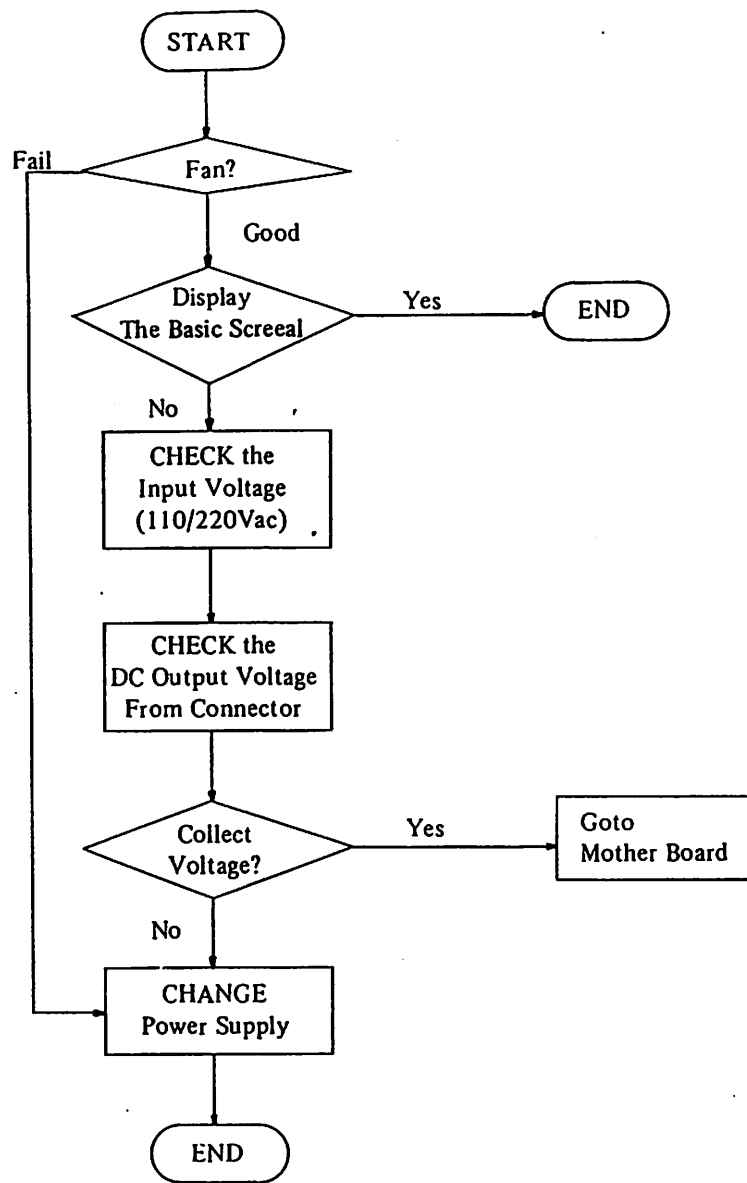

Figure 4-4. Power Supply Test Flow Chart



## Problem Isolation Procedure

### Power Supply Specifications

Model Name: PS-7  
Model Type: Switching Mode Power Supply

### Input Characteristics

Voltage Range: 95 TO 125 VAC  
190 TO 230 VAC  
(Selectable by jumper on PWB or selection switch)  
Frequency Range: 47 TO 63 Hz  
Efficiency: 65% or better under maximum voltage  
Input Current: less than 4 Amp (RMS) at full load  
Configuration: 3-WIRE INPUT AC LINE (HOT, NEUTRAL, GROUND)  
Line Regulation: +/- 0.5%  
Inrush Current: 50 Amp maximum at 115 Vac and 234 Vac

### Output Characteristics

#### DC Output

Table 4-2. DC Output

Output Voltage	Tolerance (accuracy)	Load	
		Minimum	Maximum
+5 Vdc	+/-3 %	3.0 A dc	15.0 A dc
+12Vdc	+/-4 %	0.2 A dc (peak surge 6.5 A dc)	4.2 A dc
-5 Vdc	+/-5 %	0 A dc	0.3 A dc
-12Vdc	+/-5 %	0 A dc	0.3 A dc

Voltage Adjustments The +5 volts dc output can be adjustable from 4.75V dc to 5.50V dc.

#### Load Regulation

+/- 3% for 0 to 100% load change for +5 volts output  
+/- 4% for 0 to 100% load change for +12 volts output  
+/- 5% for 0 to 100% load change for -5 volts output  
+/- 5% for 0 to 100% load change for -12 volts output

## Chapter 4

---

**OutputOvershoot** 1% maximum all output overshoot on turn-on or turn off.

**Hold-Up Time** more then 20 miliseconds

### **Environment**

**Temperature:** 0 degree C to 50 degree C (at full load)  
-20 degree C to 70 degree C (at storage)

**Humidity:** 5% to 85% (at operational)  
5% to 95% (at stroage)

**Mean Time  
Between Failures:** Greater then 50,000 hours (at 25 degree C)

### Motherboard

1. Set the power switch on the system unit to OFF.
2. Remove the power connector on the mother board.
3. Measure the short to power connector on the mother board. All points should be open.

### Short Test:

1. In the power connector:

PIN 5 to PIN 3

PIN 5 to PIN 4

PIN 5 to PIN 9

PIN 5 to PIN 10

2. In each slot:

B 1 to B 3

B 1 to B 5

B 1 to B 7

B 1 to B 9

B31 to B29

### Note:

**Remove all adapter boards on the mother board.**

Set your meter to over the 12Vdc scale. Connect the common read to pin 5. Set the power switch on the system unit to ON and check each pin.

## Chapter 4

---

### Mother Board Expansion Slot Specifications

Table 4-3. Mother Board Pinouts

Signal Name	REAL B	PANEL A	Signal Name
GND	1	1	-I/O CH CK
+RESET DRV	2	2	+D7
+5V	3	3	+D6
+IRQ2	4	4	+D5
-5VDC	5	5	+D4
+DRQ2	6	6	+D3
-12V	7	7	+D2
-CARD SLCTD	8	8	+D1
+12V	9	9	+D0
GND	10	10	+I/O CH CK
-MEMW	11	11	+AEN
-MEMR	12	12	+A19
-IOW	13	13	+A18
-IOR	14	14	+A17
-DACK3	15	15	+A16
+DRQ3	16	16	+A15
-DACK1	17	17	+A14
+DRQ1	18	18	+A13
-DACK0	19	19	+A12
CLOCK	20	20	+A11
+IRQ7	21	21	+A10
+IRQ6	22	22	+A9
+IRQ5	23	23	+A8
+IRQ4	24	24	+A7
+IRQ3	25	25	+A6
-DACK2	26	26	+A5
+T/C	27	27	+A4
+ALE	38	28	+A3
+5V	29	29	+A2
+OSC	30	30	+A1
+GND	31	31	+A0

Component Side

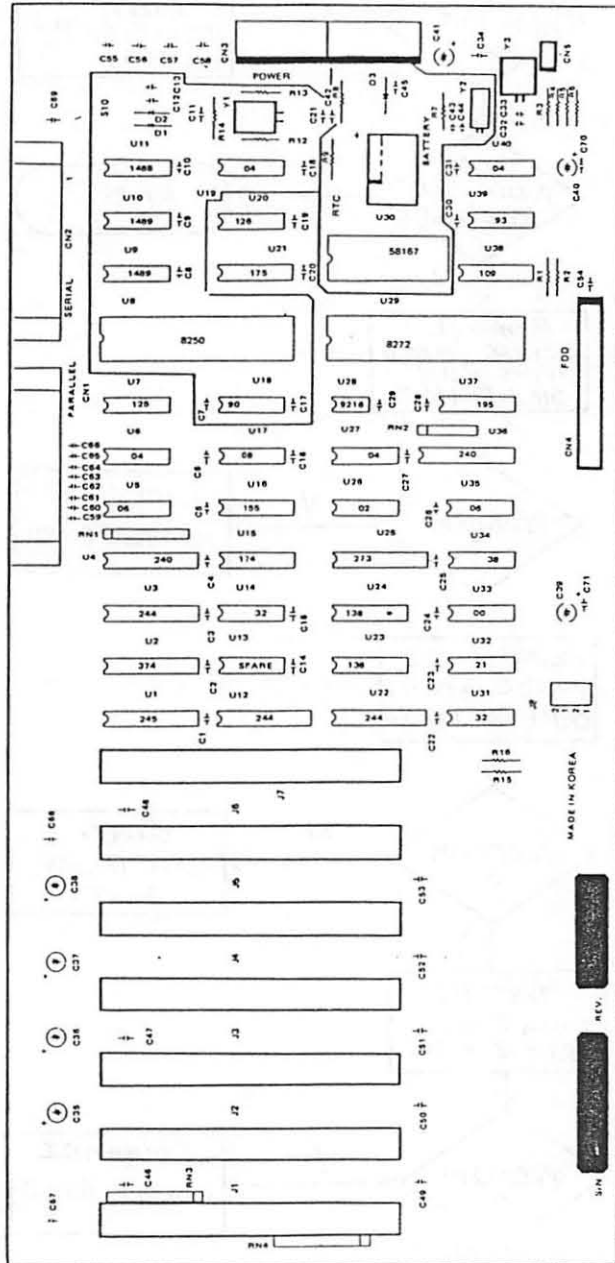

Figure 4-5. Mother Board Figure Parts Arrangement Plan

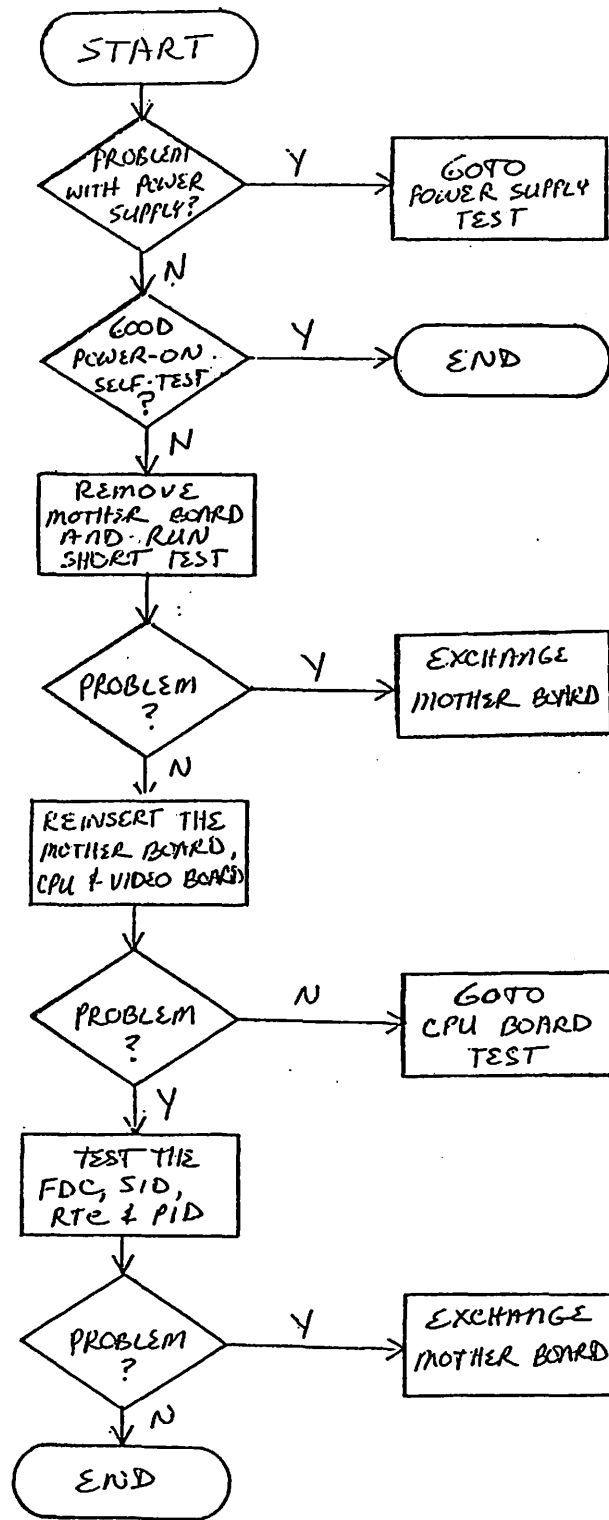

Figure 4-6. Mother Board Test Flow Chart

## Real-Time Clock

The system uses the MM-58167 (National Semiconductor) clock. The device includes an addressable real time counter, 56 bits of RAM, and two interrupt outputs.

### Specifications

- 32.768 Hz crystal
- 3.6 Vdc rechargeable battery
- I/O address map : 0300H - 031FH

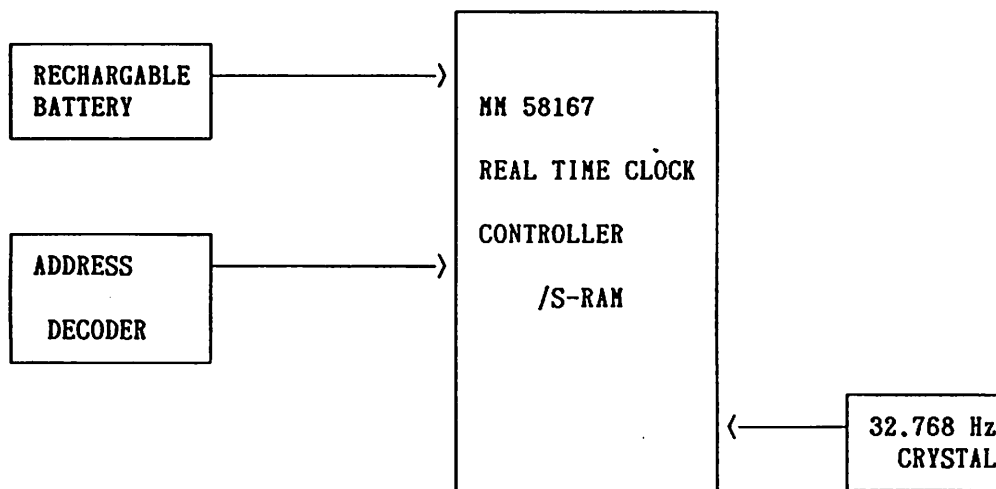

Figure 4-7. Real-Time Clock Block Diagram

## Chapter 4

---

### Keyboard Specifications

Power Requirement:	+5VDC @ 240mA normal
Interface Protocol:	Data protocol is serial format TTL.
Mechanical Data:	Operating life: 50 mega cycles
Sense of touch:	Foam pad positive tactile
Environmental Data:	Operating temperature: 0 to 55 degrees (C)
Relative Humidity:	20% - 95% non-condensing
Altitude:	-1000ft to 10000ft

**Table 4-4. Keyboard Interface Connector**

Description	Voltage	Pins	Connector
Keyboard Clock	+5VDC Signal	1	
Keyboard Data	+5VDC Signal	2	
Keyboard Reset	0	3	
Ground	0	4	
Power Supply	+ 5 VDC	5	



### Printer Adapter (Centronics Standard, Parallel Port)

The printer port is specifically designed to attach printers with a parallel port interface, but it can be used as a signal input/output for any device or application that matches its input/output capabilities. It has 12 TTL-buffer output points, which latch and can be written and read under program control using the processor In or Out instruction. The port also has five steady state input points that may be read using the processor's In instruction.

In addition, one input can also be used to create a processor interrupt. This interrupt can be enabled and disabled under program control. Reset from the receive a power on reset when the processor is reset.

The input/output signals are made available at the back of the port through a right-angled, PCB mounted, 25-pin D-shell connector. This connector protrudes through the rear panel of the system unit where a cable may be attached.

When this port is used to attach a printer, data or printer commands are loaded into an 8-bit, latched, output port, and the strobe line is activated. Printer status indicates when the next character can be written or it may use the interrupt line to indicate "not busy" to the software.

The output ports may also be read at the card's interface for diagnostic loop functions. This allows faults to be isolated between the port and the attached printer.

Table 4-5. Parallel Port Pinouts

Pin	Description
1	-Strobe
2	+Data Bit 0
3	+Data Bit 1
4	+Data Bit 2
5	+Data Bit 3
6	+Data Bit 4
7	+Data Bit 5
8	+Data Bit 6
9	+Data Bit 7
10	-Acknowledge
11	+Busy
12	+P.End
13	+Select
14	-Auto Feed
15	-Error
16	-Initialize Printer
17	-Select Input
18-25	Ground

## Chapter 4

---

### 5-1/4" Disk Drive Controller

This controller attaches to one or two disk drives through an internal, daisy-chained flat cable that connects to one end of the drive adapter. This connector has signals for two disk drives; thus, the 5-1/4 inch disk drive adapter can attach two 5-1/4 inch drives.

The controller is designed for double density, MFM-coded, disk drives and uses write precompensation with an analog phase-clock loop for clock and data recovery. The controller is a general purpose device using a NEC uPD765 (or INTEL 8272) compatible controller. Therefore, the disk drive parameters are programmable. In addition, the attachment supports the disk drive's write-protect feature. The controller is buffered on the I/O bus and uses the CPU board's direct memory access (DMA) for record data transfers. An interrupt level is also used to indicate when an operation is complete and that a status condition requires processor attention. In general, the 5-1/4 inch disk drive adapter presents a high-level command interface to software I/O drivers.

Disk Adaptor

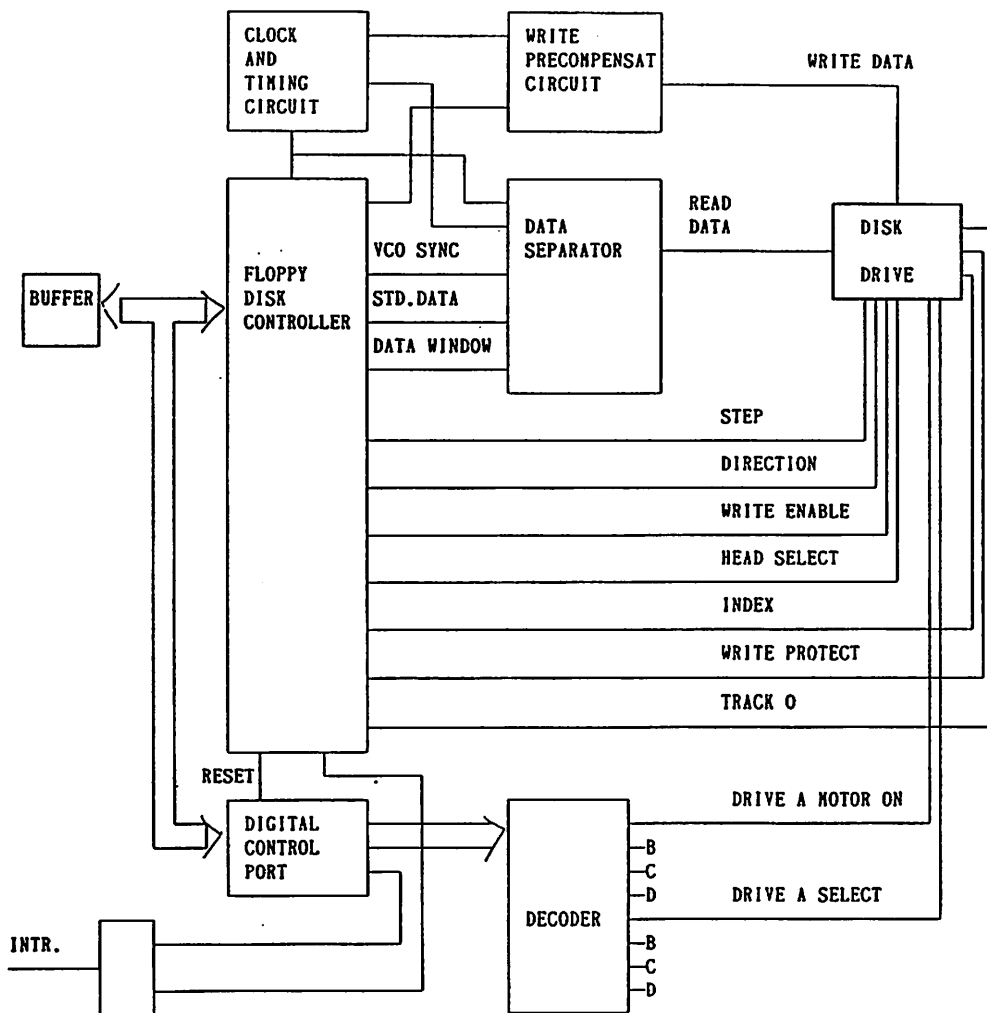

Figure 4-8. Fixed Disk Adapter Block Diagram

## Chapter 4

---

### Connector Specification

Table 4-6. Disk Drive Controller Pinouts

Land Number	Description
1-33	Ground-Odd Numbers
2,4,6	Not Used
8	Index
10	Drive Select A
12	Drive Select B
18	Not Used
20	Direction
22	Disk Step Pulse
24	Write Data
26	Write Enable
28	Track 0
30	Write Protect
32	Read Data
34	Not Used

## Problem Isolation Procedure

---

### Diskette Drive Specifications

Capacity: Total Storage (Capacity/Disk)  
Unformatted (byte) : 500,000  
Formatted (byte) : 327,680

Storage (Capacity/Surface)  
Unformatted (byte) : 250,000

Storage (Capacity/Track)  
Unformatted (byte) : 6,250  
Formatted (byte) : 4,096

Storage (Capacity/Sector)  
Formatted (byte) : 256/512

Recording Density: Number of Head : 2

Number of Track : 80

Recording Density (bpi) : 5,876

Track Density (tpi): 48

Data Transfer Rate (Kbit/s) : 250

Access: Rotational Speed (R.P.M.) : 300

Track to Track Seek (ms) : 4

Settling Time (ms) : 15

Motor Start Time (ms) : 500

**Table 4-7. Diskette Drive Power Requirements**

+12Vdc	Voltage	12V +/- 10% Maximum Ripple 100 mVpp
	Current	Maximum 0.6A/Peak 0.9A Typical 0.36A
+5Vdc	Voltage	5V +/- 5% Maximum Ripple 50mVpp
	Current	Maximum 0.65A Typical 0.5A

### Asynchronous Communication Port (Serial Port) (Without Current Loop)

The port is fully programmable and supports asynchronous communications only. It will add and remove start bits, stop bits, and parity bits. A programmable baud rate generator allows operation from 50 baud to 9600 baud. Five, six, seven or eight bit characters with 1, 1-1/2, or 2 stop bits are supported. A fully prioritized interrupt system controls transmit, receive, error, line status and data set interrupts. Diagnostic capabilities provide a loopback function of transmit or receive and input or output signals.

- Features in addition to those listed above:
- Full double buffering which eliminates the need for precise synchronization.
- Independent receiver clock input.
- Modem control functions: clear to send (CTS), request to send (RTS), data set ready (DTR), ring indicator (RI), and carrier detect.
- False-start bit detection.
- Line-break generation and detection.

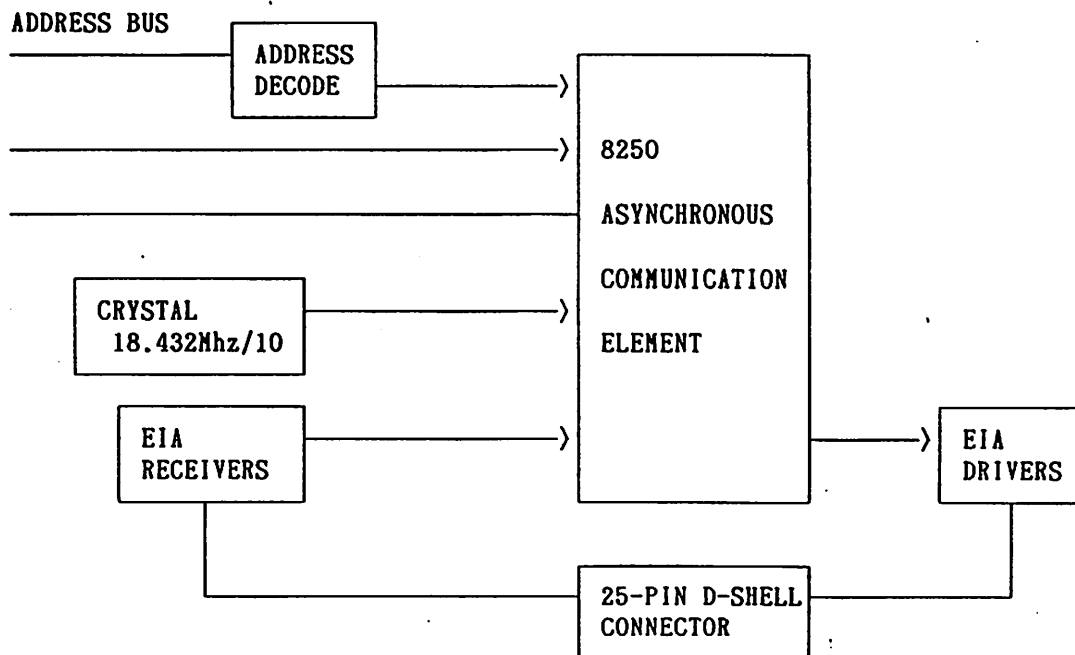

Figure 4-9. Asynchronous Communication Port Block Diagram

Table 4-8. Serial Port Connector Pinouts

Pin	Description
1	Not Used
2	Transmitted Data
3	Received Data
4	Request to Send
5	Clear to Send
6	Signal Ground
7	Received Line Signal Detector
8	Not Used
9	Not Used
10	Not Used
11	Not Used
12	Not Used
13	Not Used
14	Not Used
15	Not Used
16	Not Used
17	Not Used
18	Not Used
19	Not Used
20	Data Terminal Ready
21	Not Used
22	Ring Indicator
23	Not Used
24	Not Used
25	Not Used



### Serial Port

**ESI RS232 Serial Port Test Plug (connector DB-25S)**

Connect Pin 2 to Pin 3

Connect Pin 4 to Pin 5

Connect Pin 6 to Pin 8 to Pin 20

### Parallel Port

**ESI Parallel Port Test Plug (connector DB-25P)**

Connect Pin 1 to Pin 13

Connect Pin 9 to Pin 15

Connect Pin 10 to Pin 16

Connect Pin 11 to Pin 17

Connect Pin 12 to Pin 14

## Chapter 4

---

### Parts List for the TURBO-888-XT

1. CPU Board Assembly
2. Mother Board Assembly
3. Memory Board Assembly
4. Video Board Assembly
5. Power Supply Related Parts
  - 5-1. Fuse
  - 5-2. Power Switch
  - 5-3. Power Supply Assembly
6. Floppy Drive
7. Hard Disk Drive (optional)
8. Hard Disk Controller (optional)
9. Cables
  - 9-1. Flat Cable - Floppy Drive
  - 9-2. Flat Cable - Hard Drive
  - 9-3. Power Cord
  - 9-4. Keyboard Harness

## Chapter 5. External and Internal View

Locations

System Unit

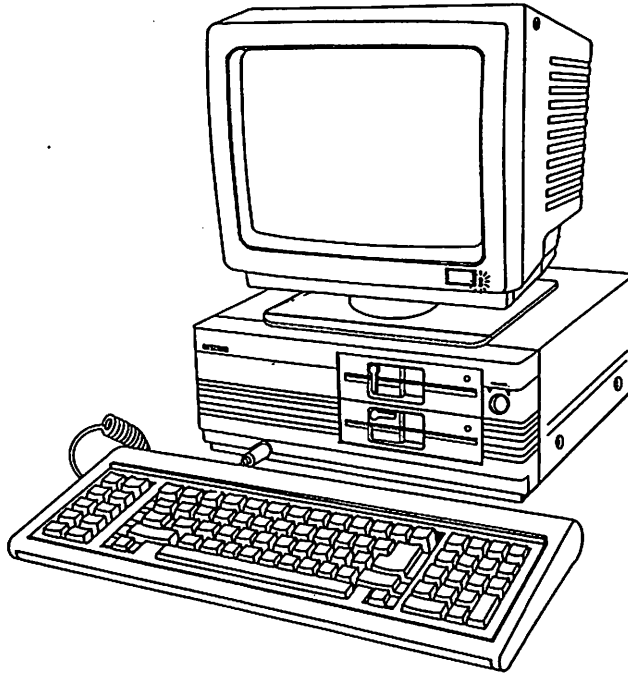

**Figure 5-1. VENDEX Turbo 888-XT Standard System Configuration**

Front Panel

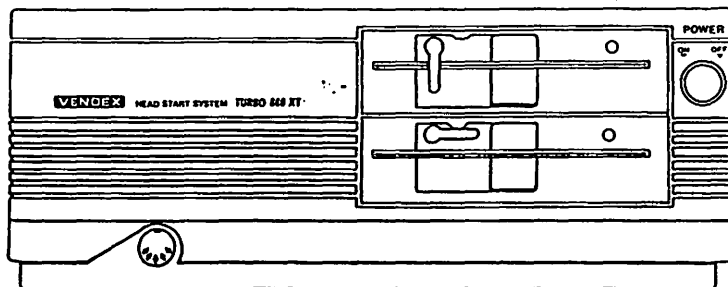

Figure 5-2. Front Panel

System Unit Interior View

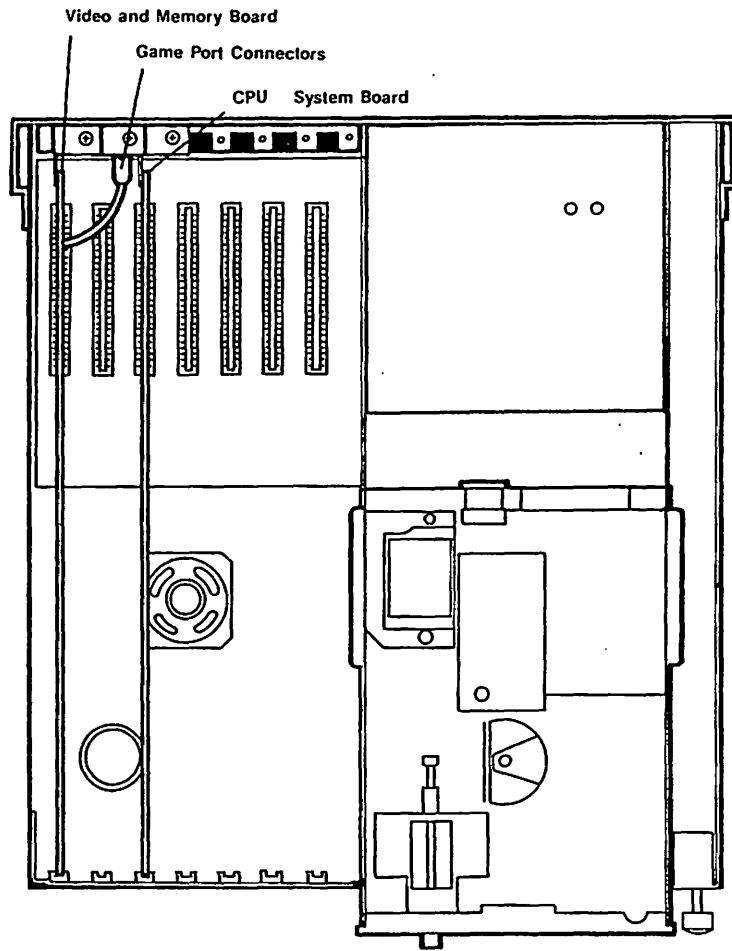

Figure 5-3. Internal View of System Unit

## Chapter 5

---

### Rear Panel

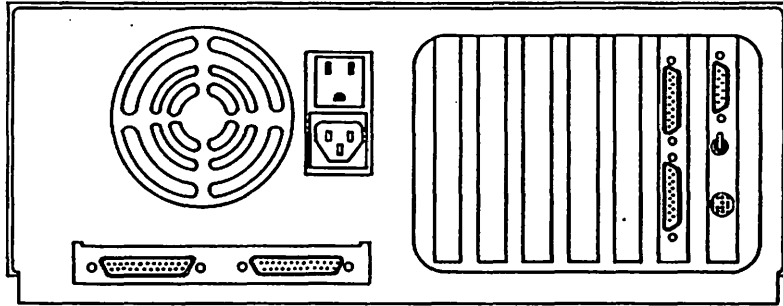

Figure 5-4. Rear Panel of Sytem Unit

Keyboard

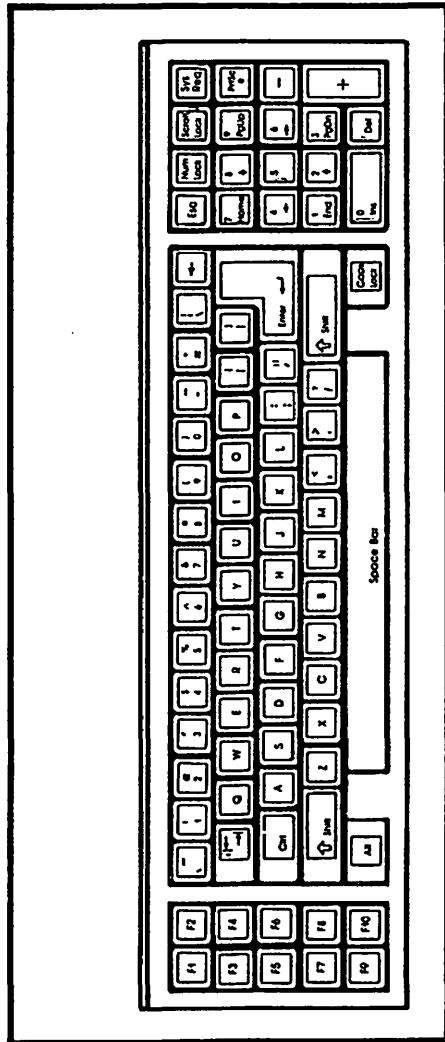

Figure 5-5. Keyboard

## ERRATA SHEET

Please note the following correction to the Video Display Adapter Switch Settings shown on page 11 of the Vendex Headstart Computer System Addendum.

The factory switch settings for the Video Display Adapter are shown below:

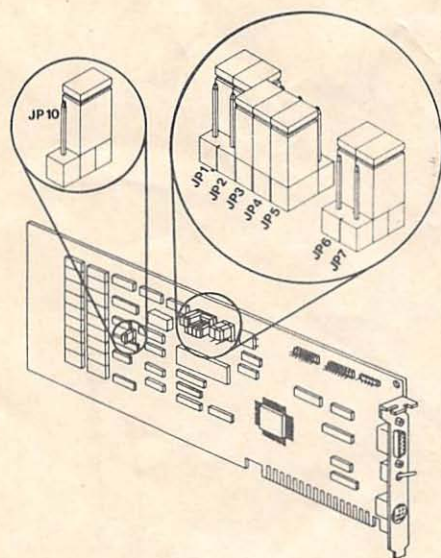

Figure B-2. Video Adapter Jumper Switch Location (Factory Settings)

Table B-2. Video Adapter Jumper Switch Settings

Switch	Up Position	Down Position
JP1	Enable Mouse	Disable Mouse
JP2	Mouse IRQ2	Mouse Not IRQ2
JP3	Mouse IRQ3	Mouse Not IRQ3
JP4	Mouse IRQ4	Mouse Not IRQ4
JP5	Mouse IRQ5	Mouse Not IRQ5
JP6	Enable Game	Disable Game
JP7	Positive Hsync	Negative Hsync
JP10	Bank Port = 374H	Bank Port = 274H



# Appendix A. Schematics

MOTHER BOARD

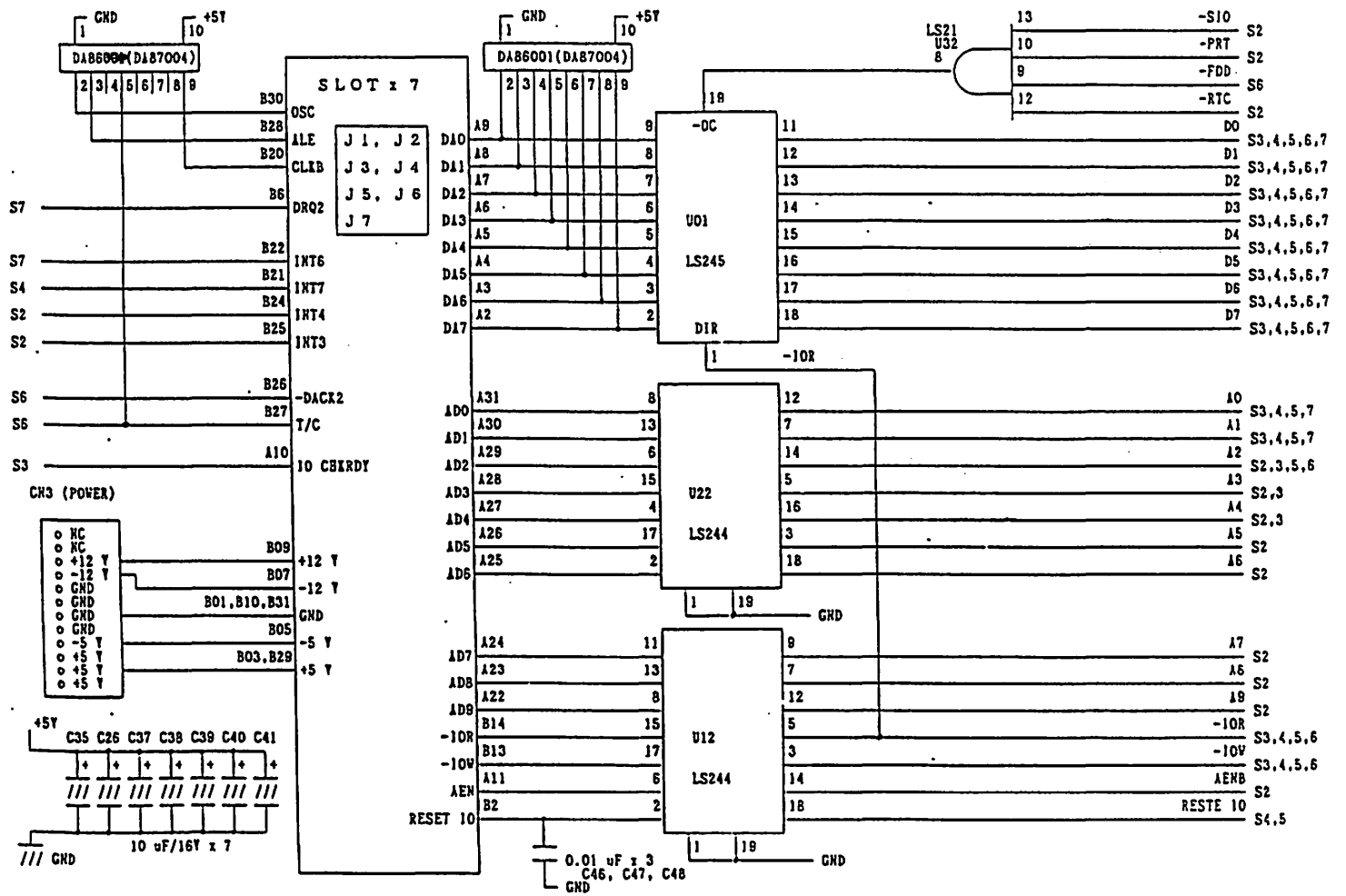

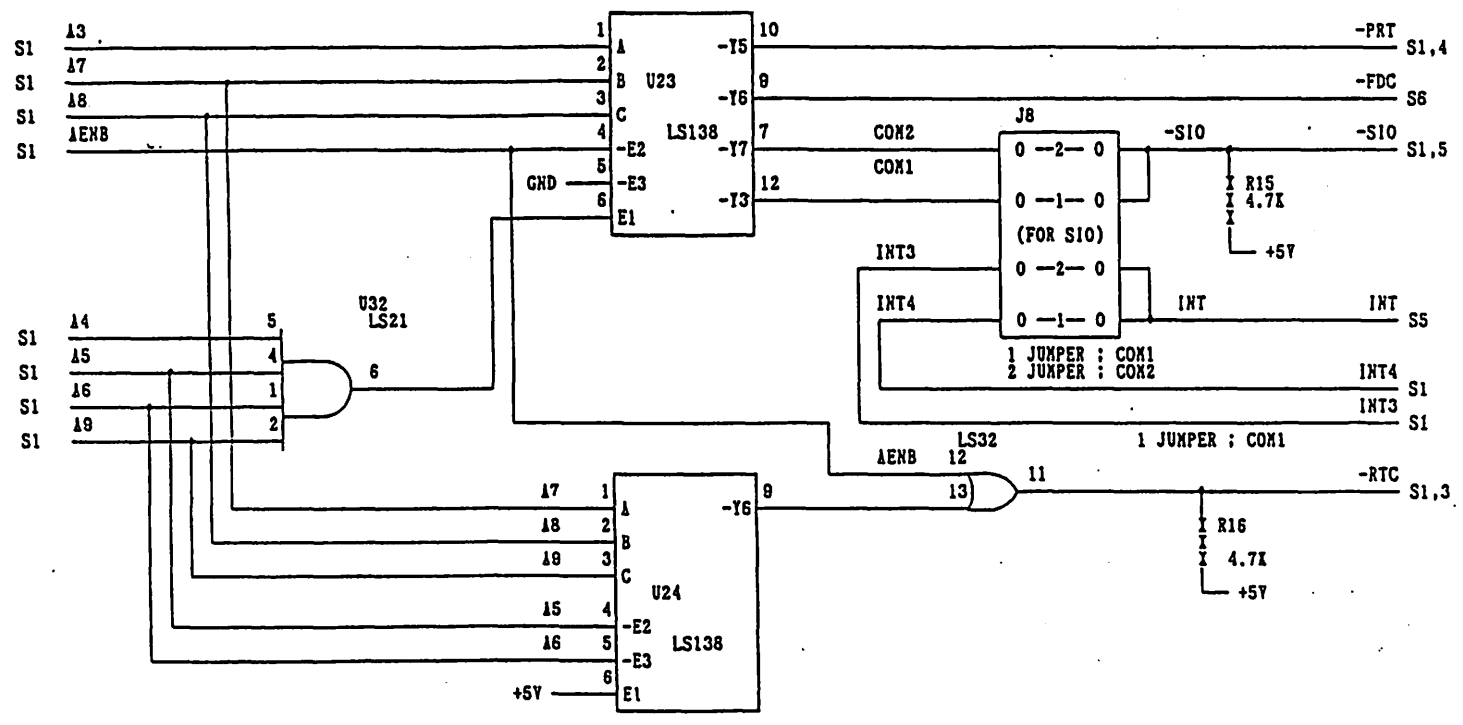

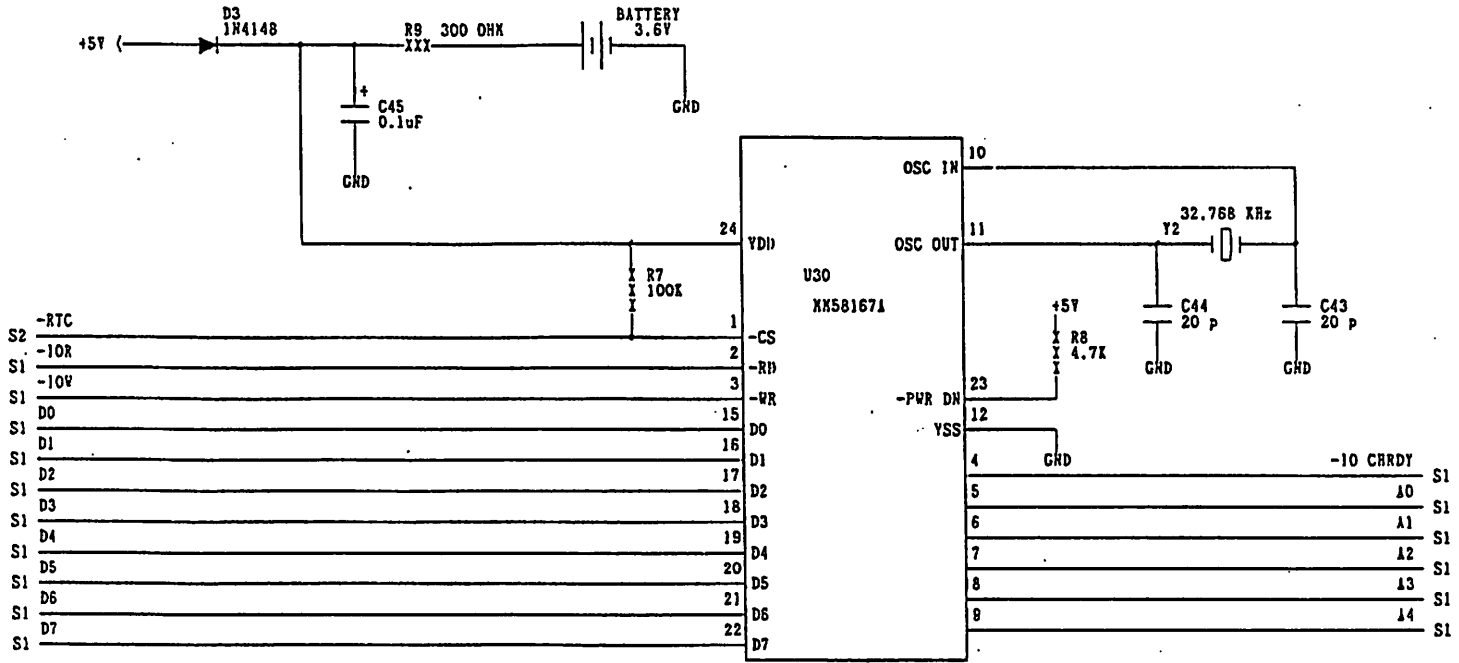

# Appendix A

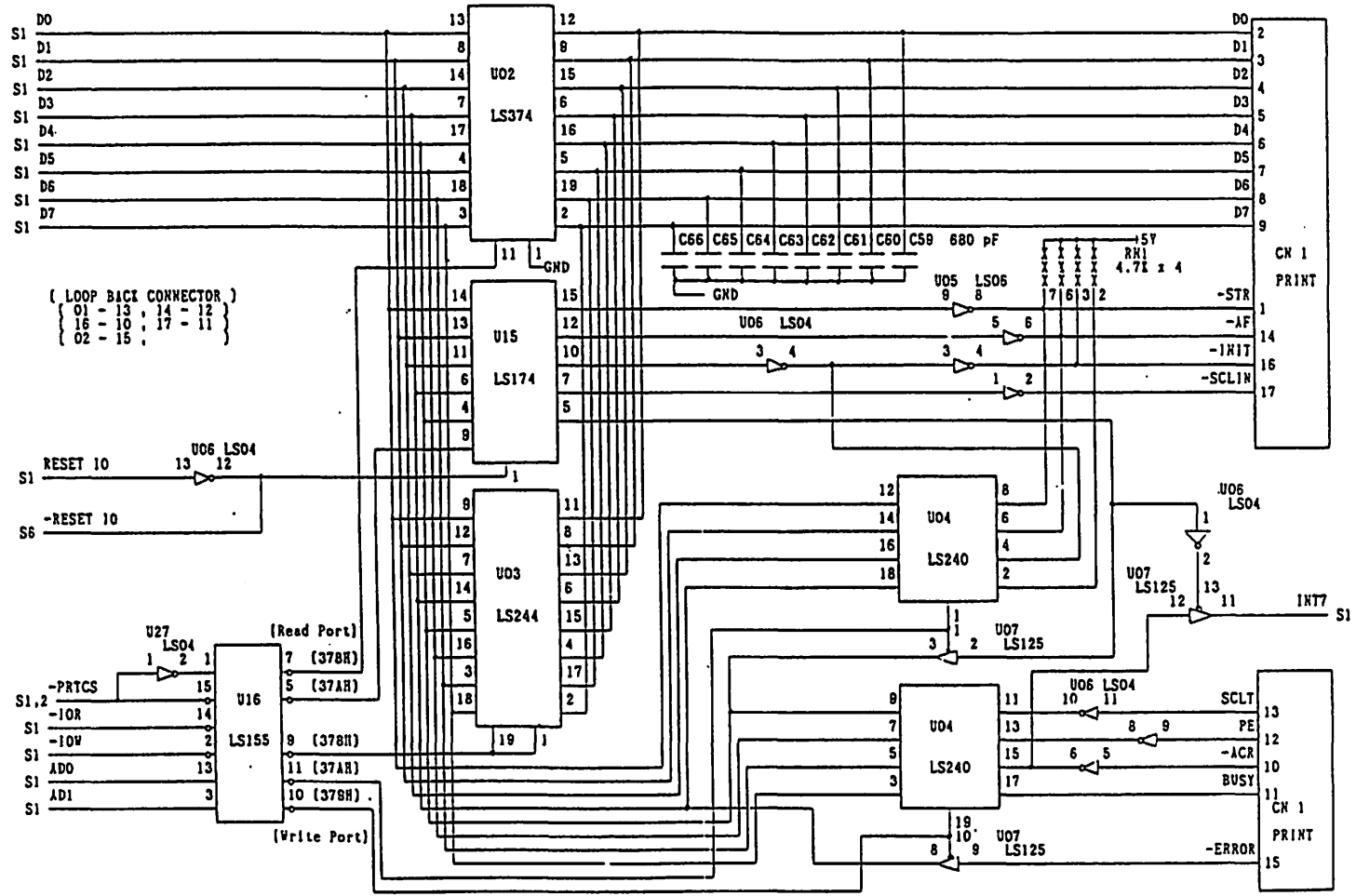



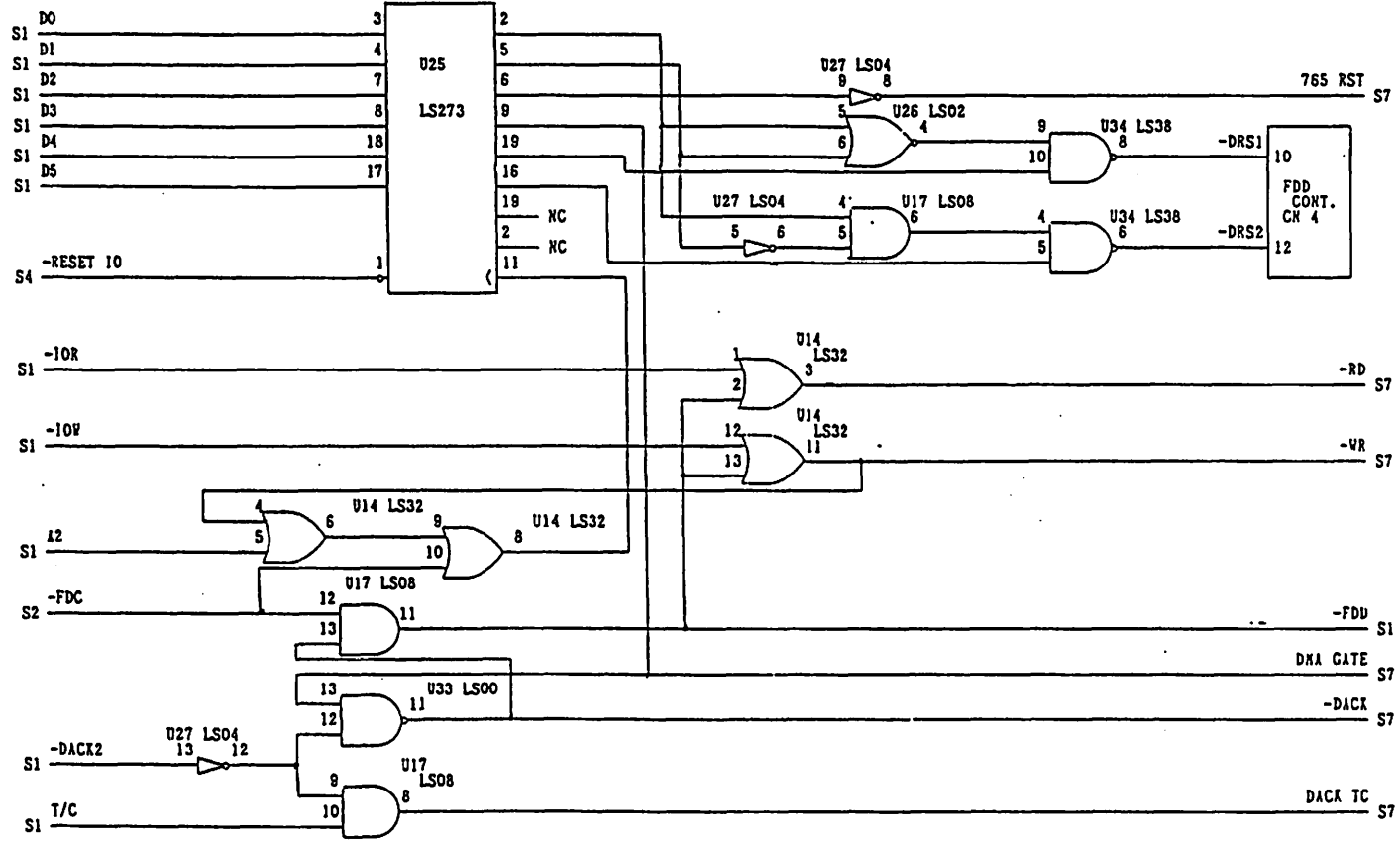

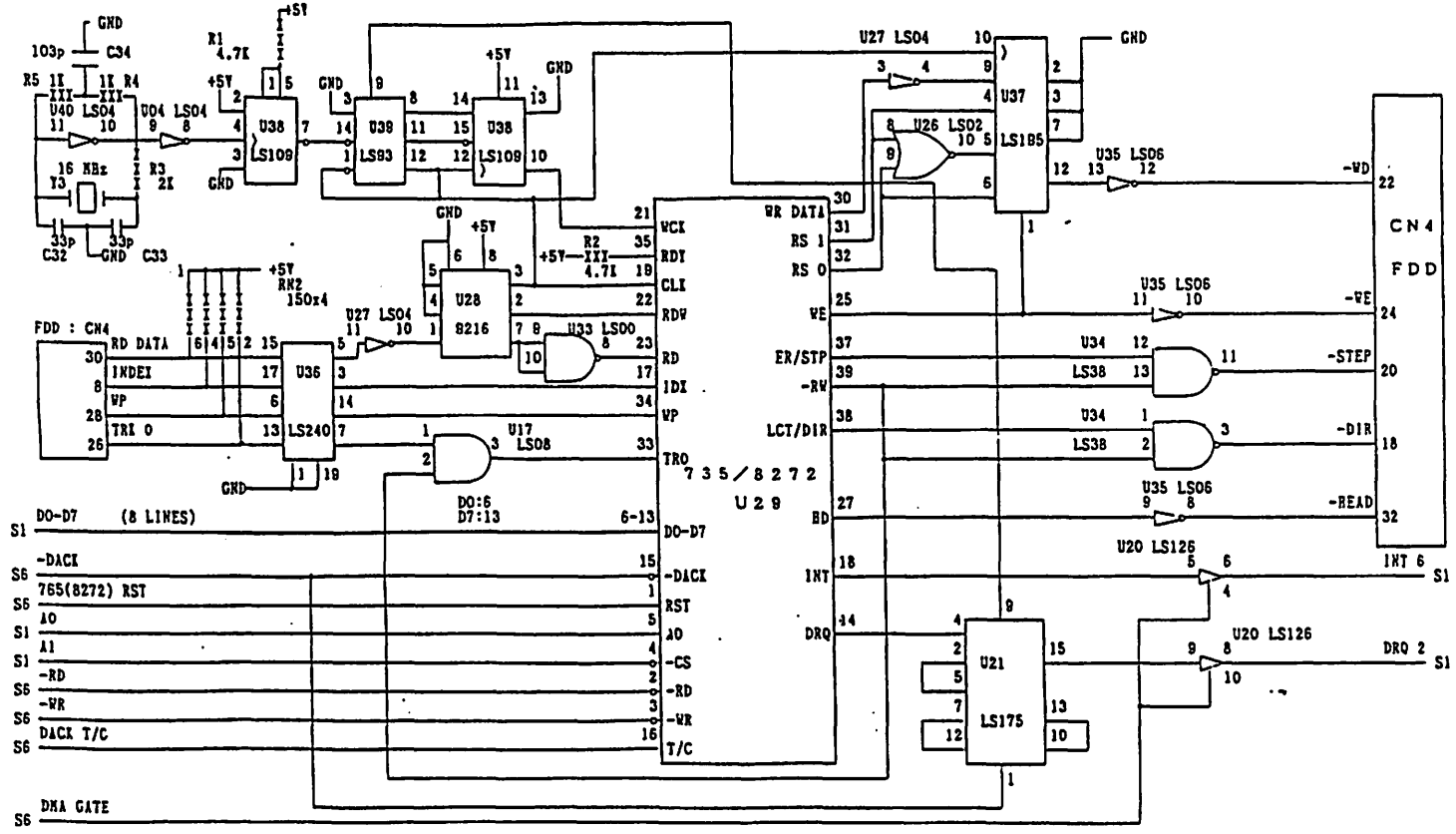





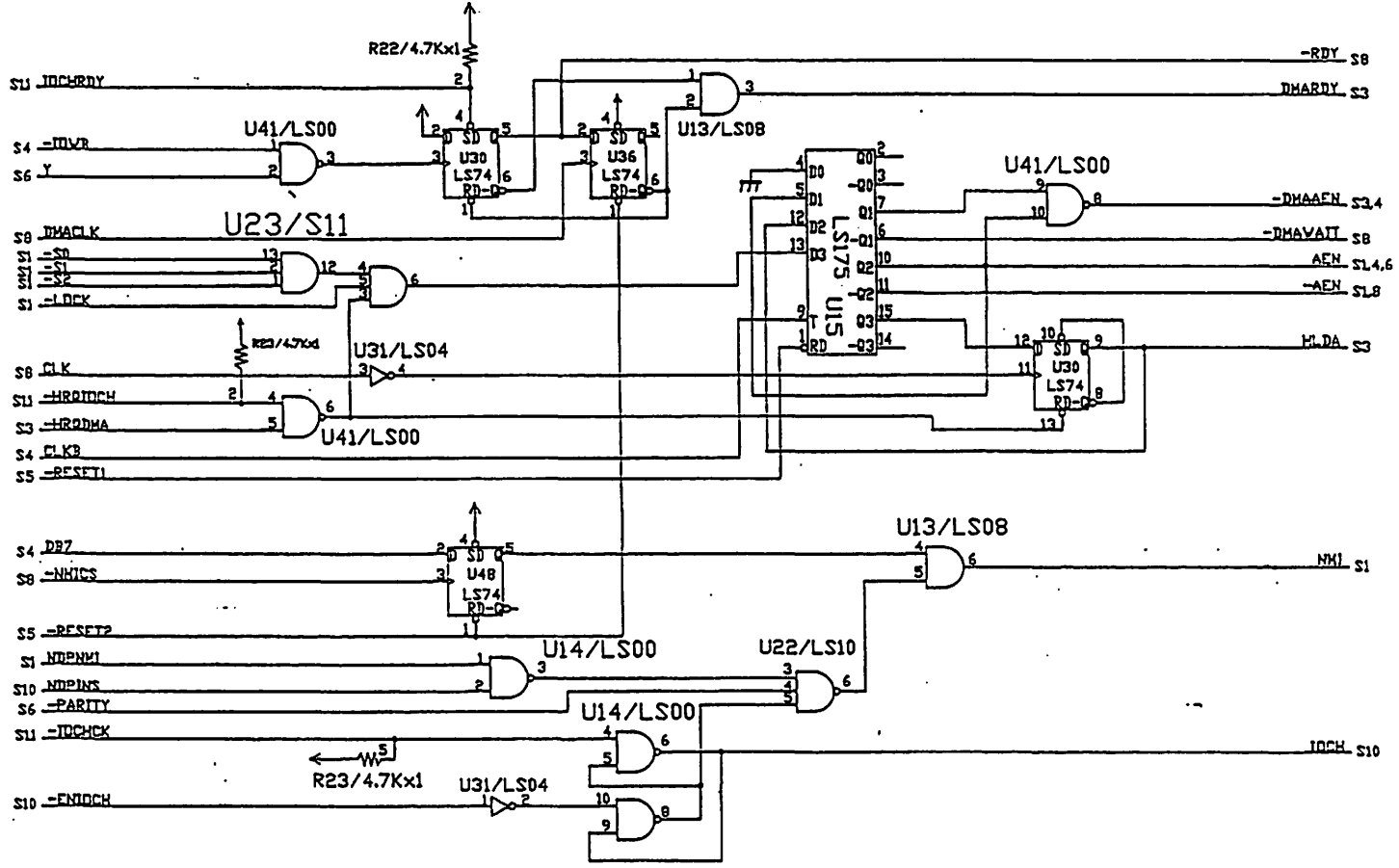

Appendix A

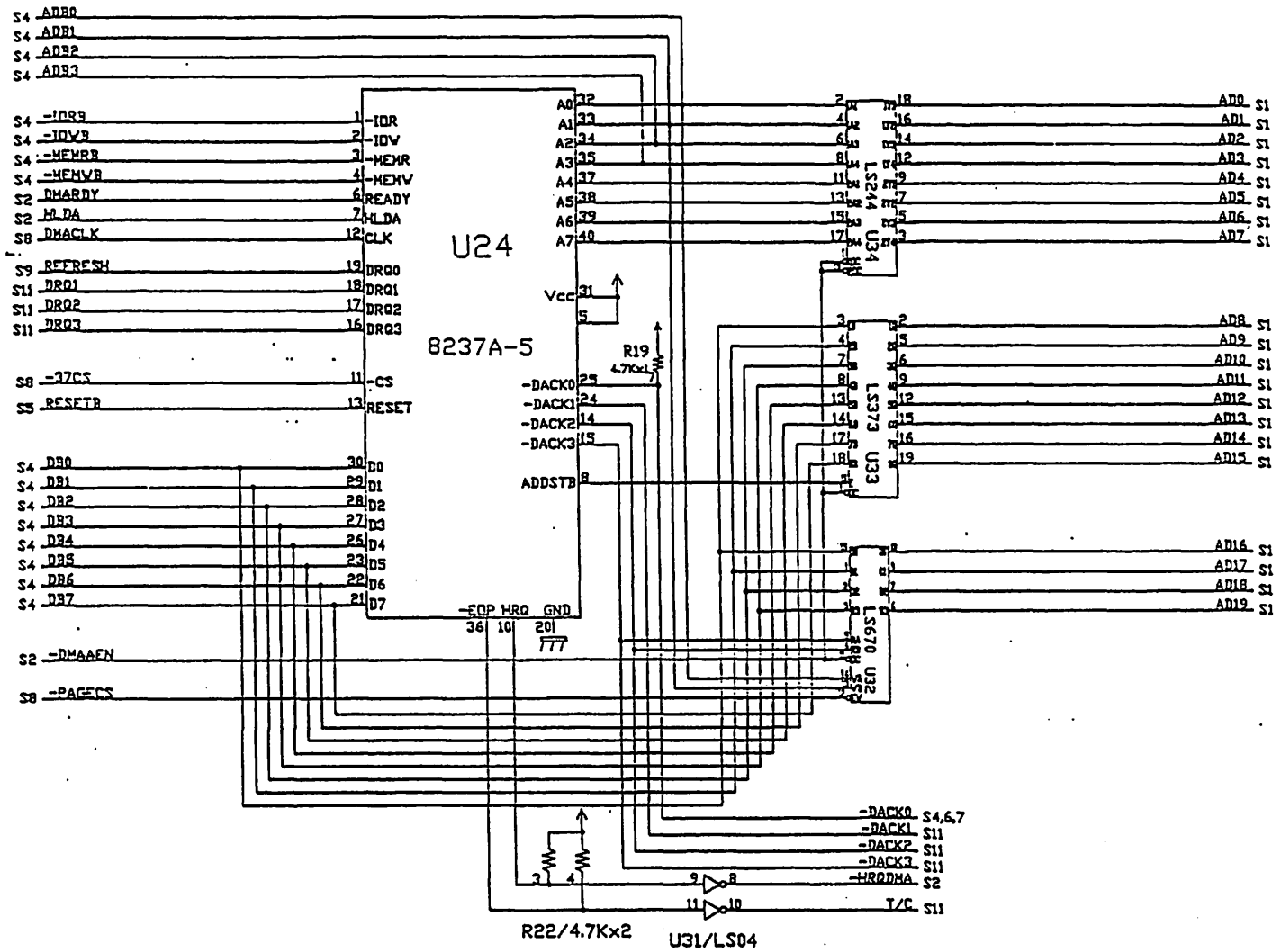

# Schematics

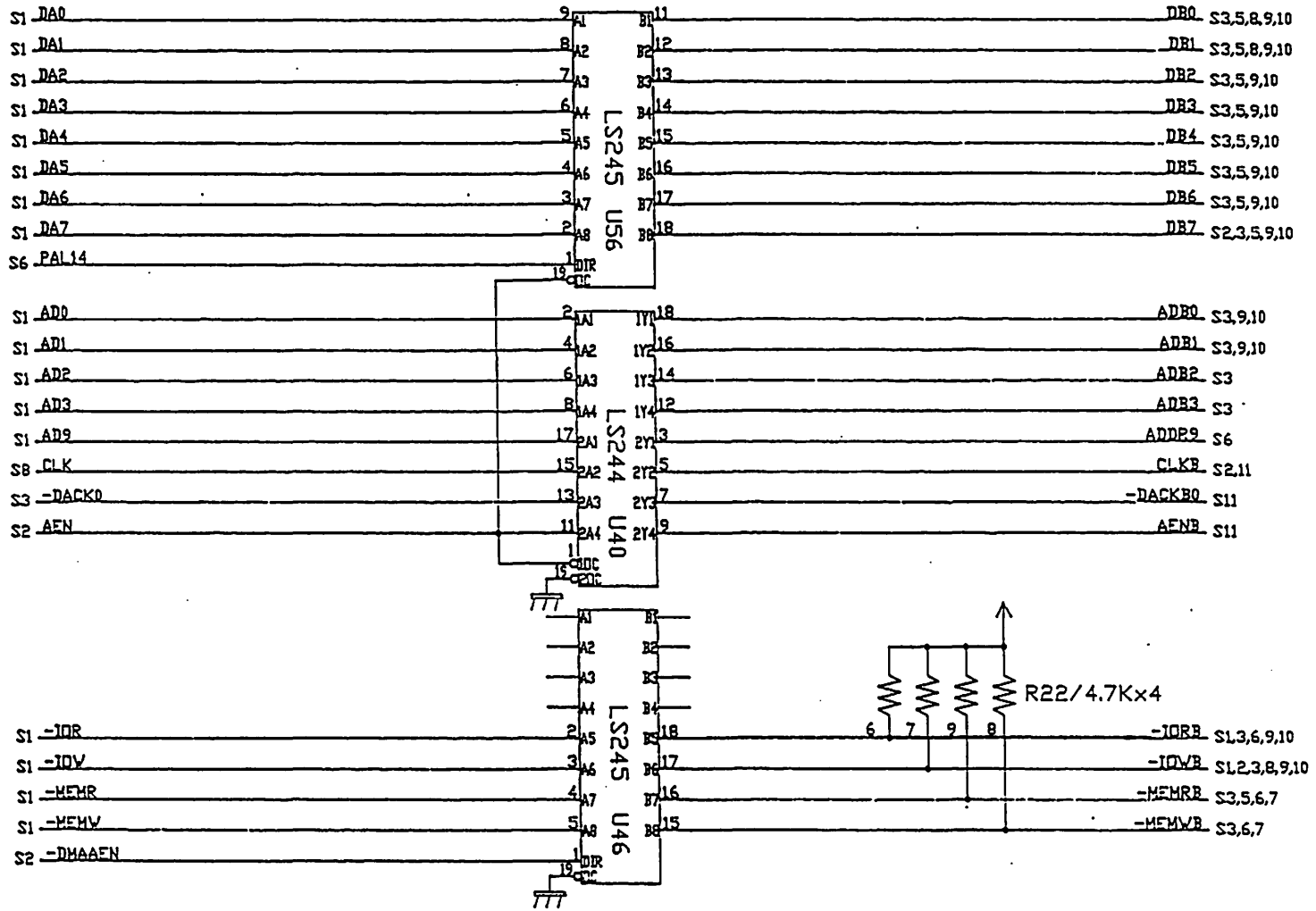

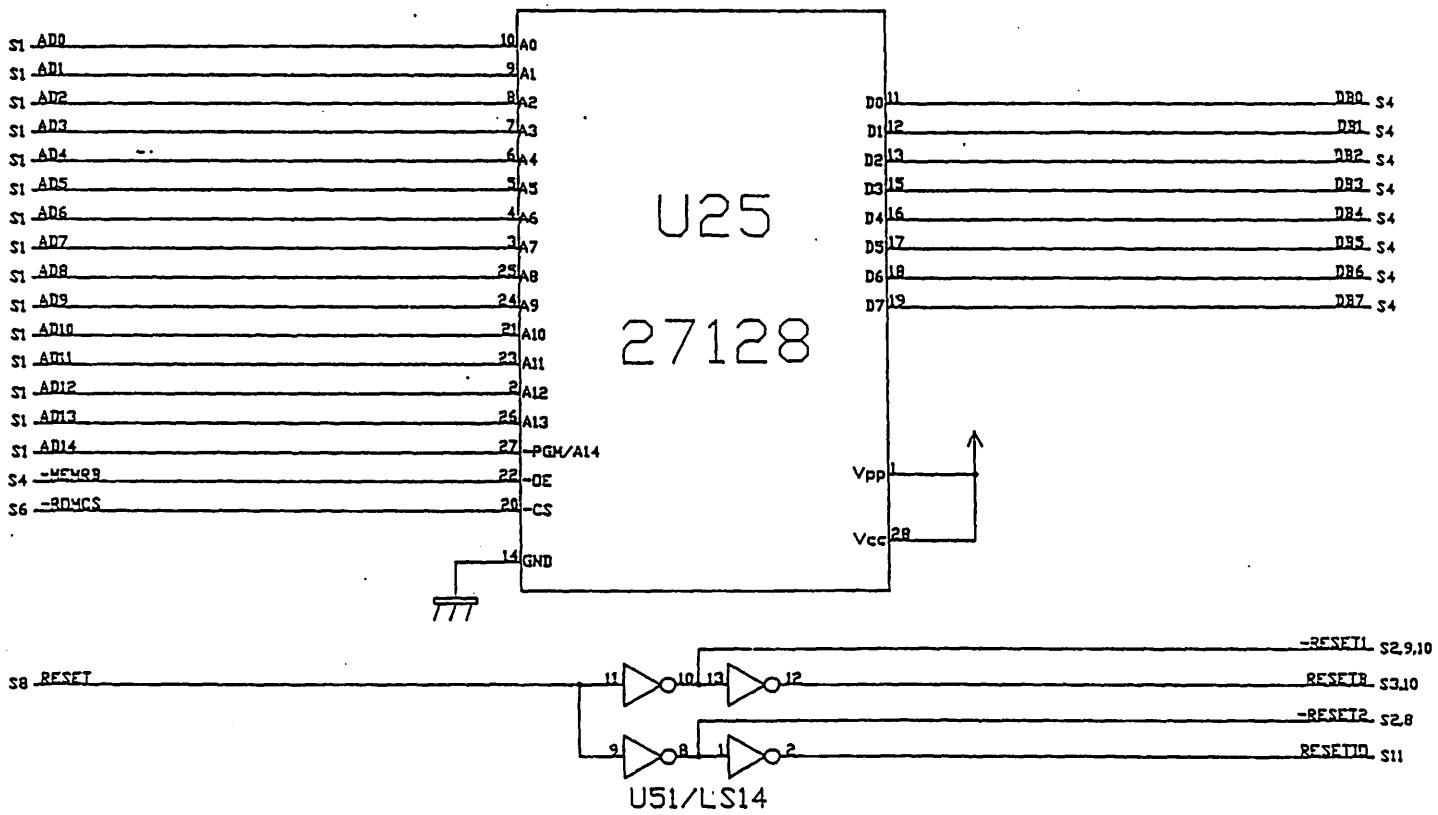

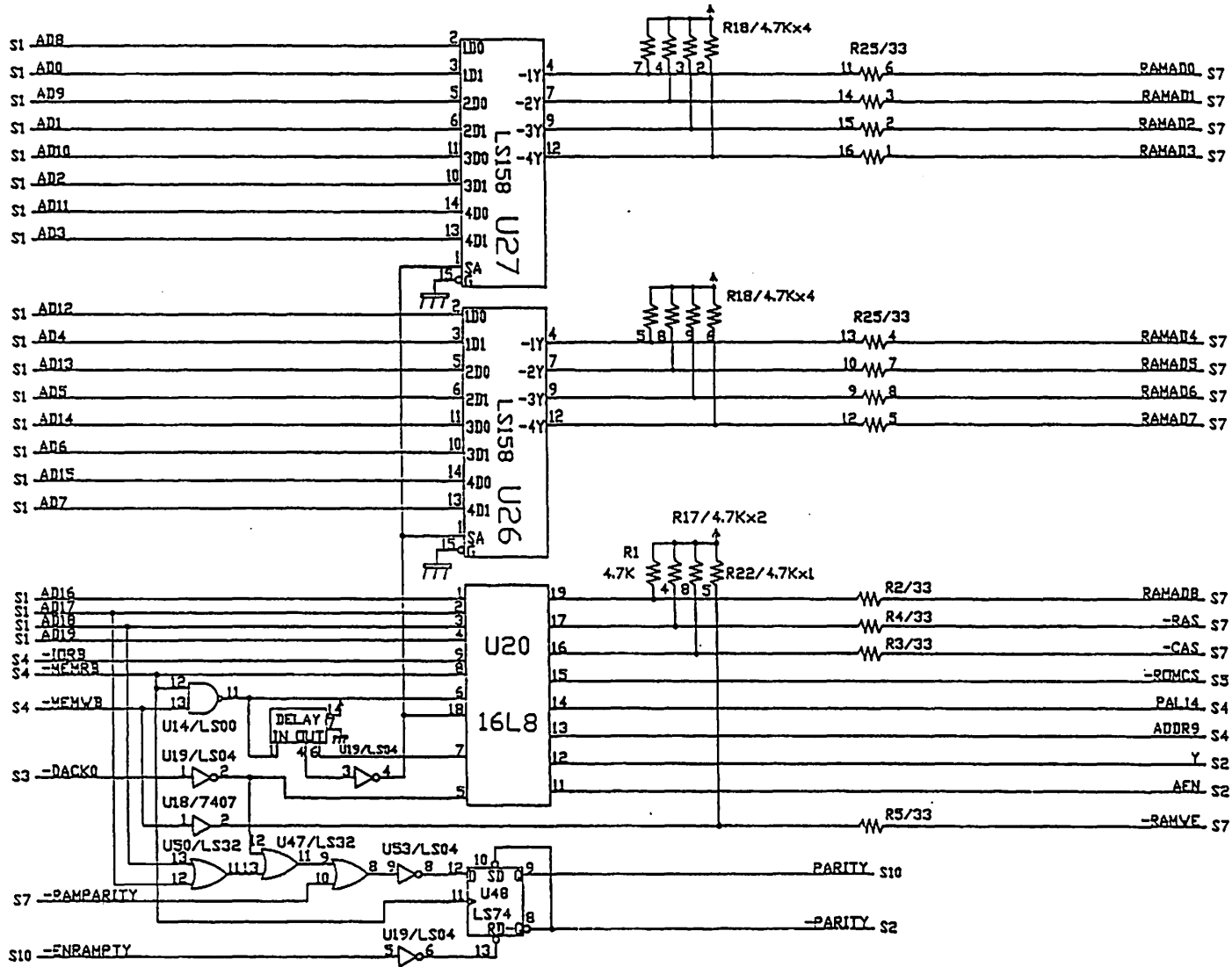

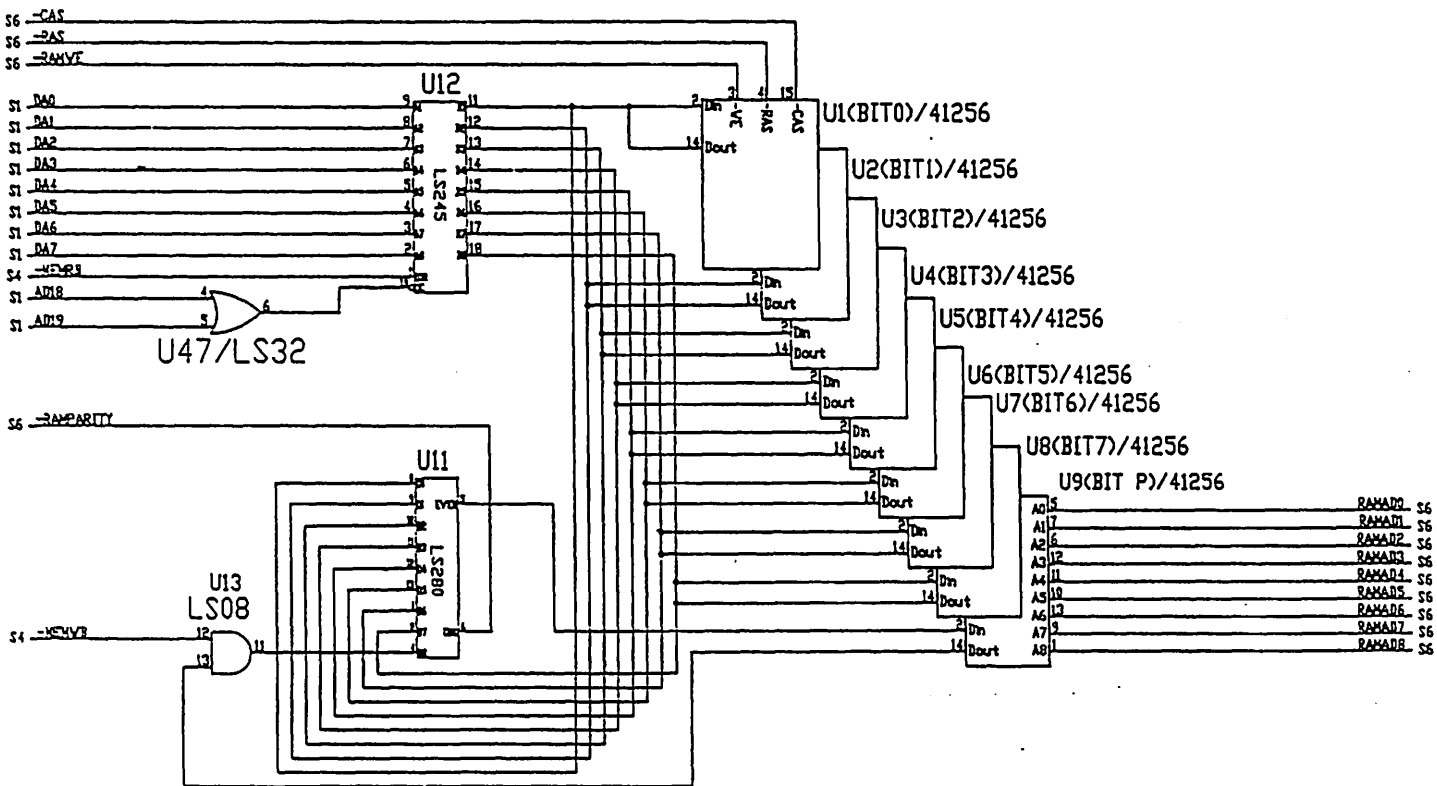

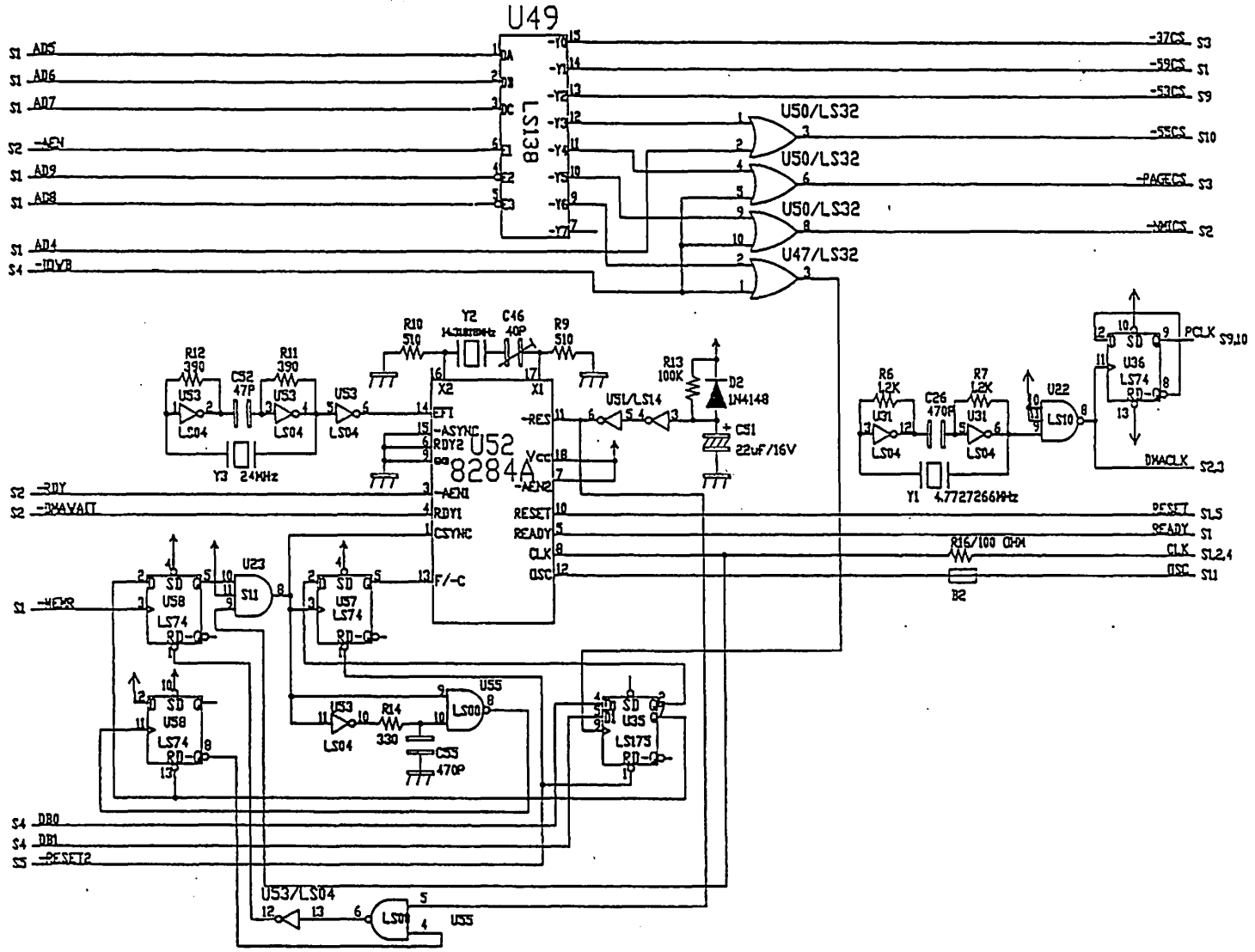

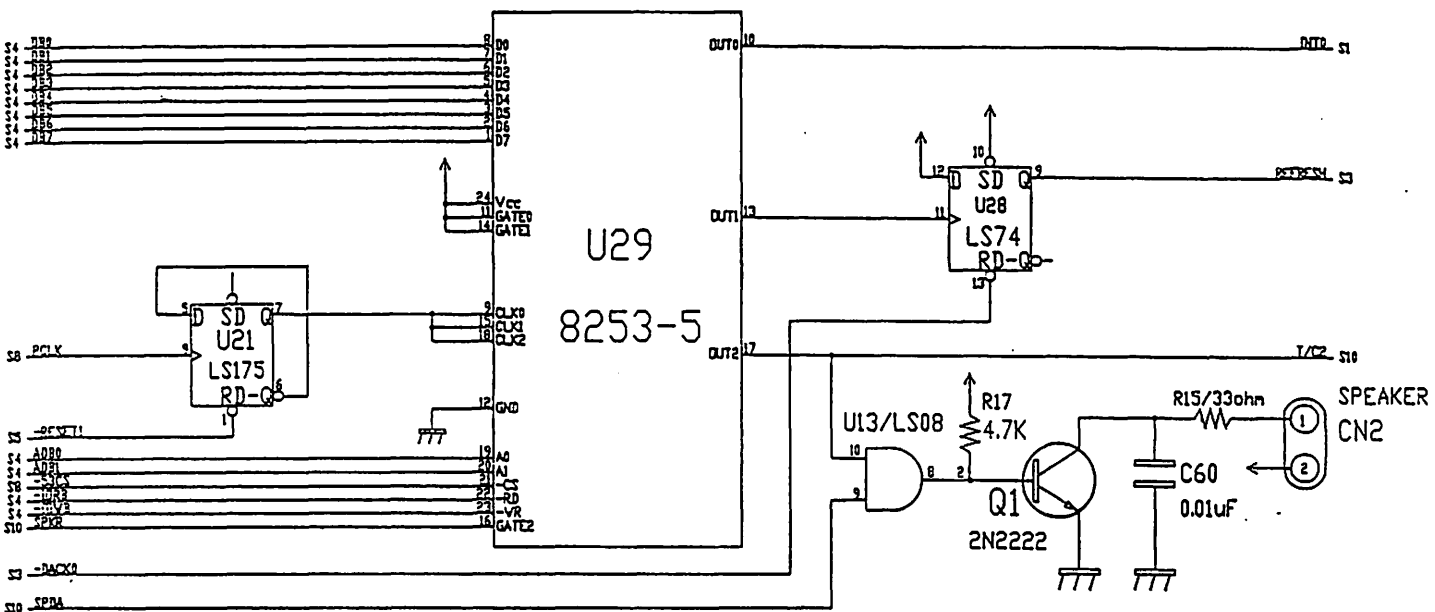



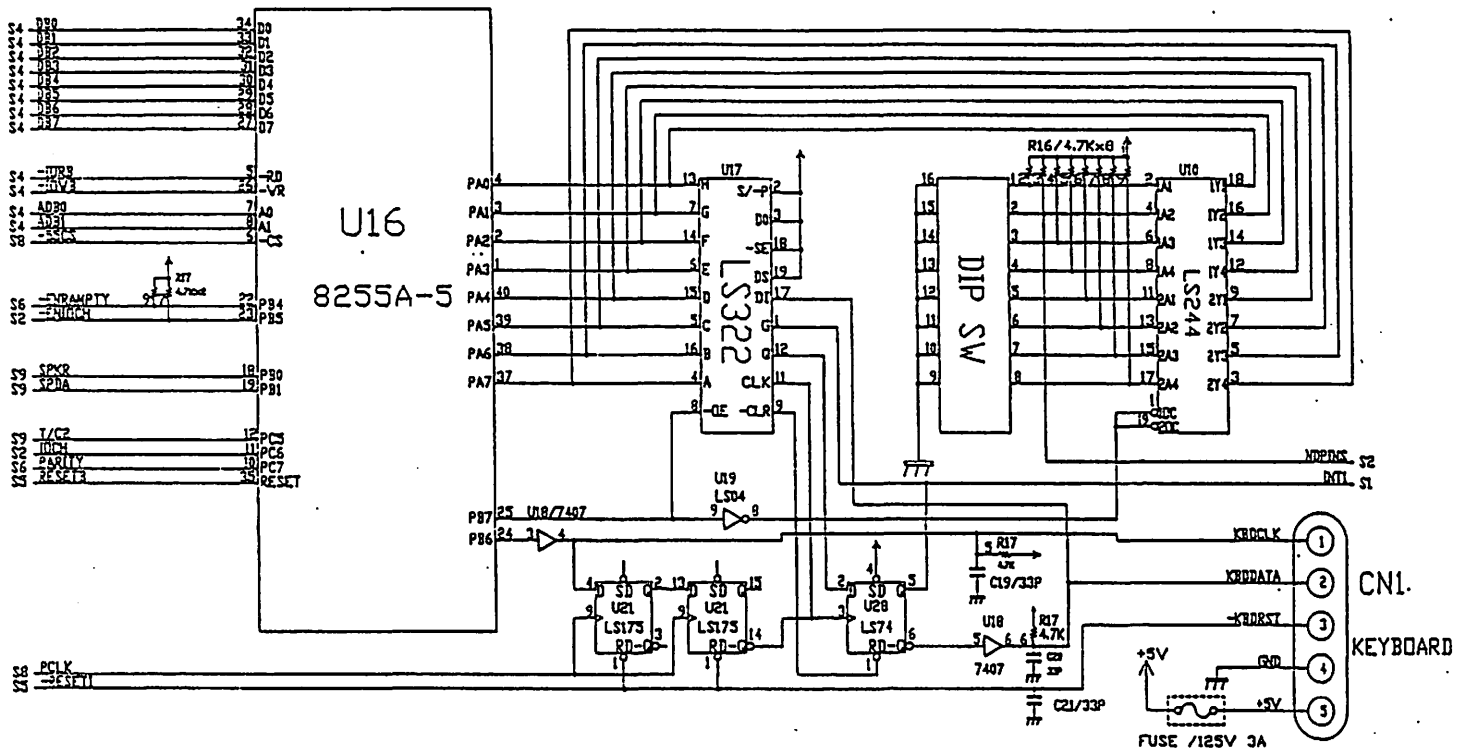

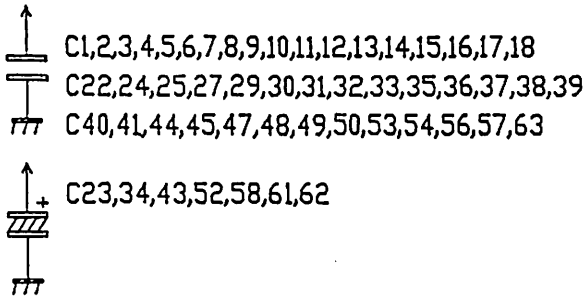
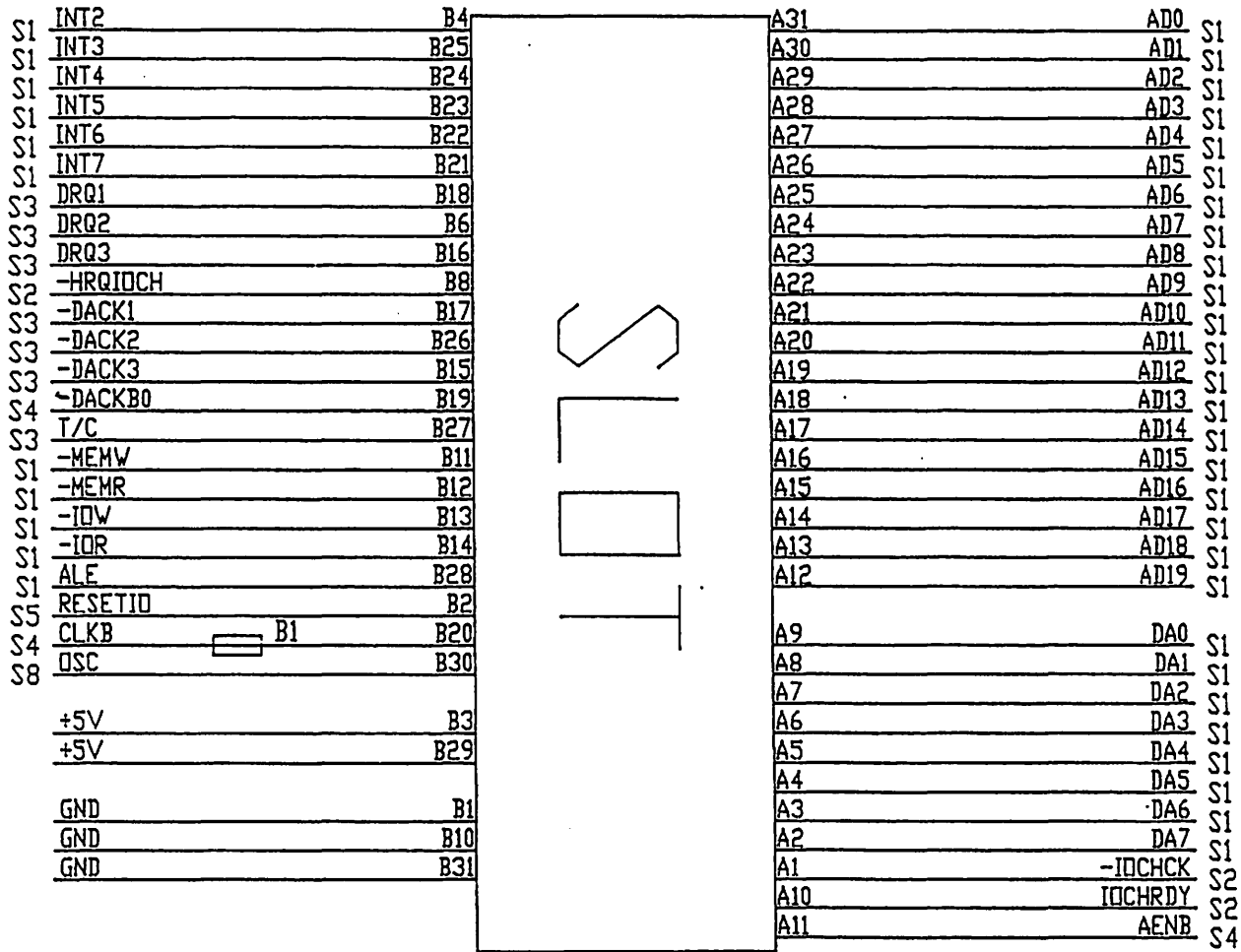

DISPLAY BOARD

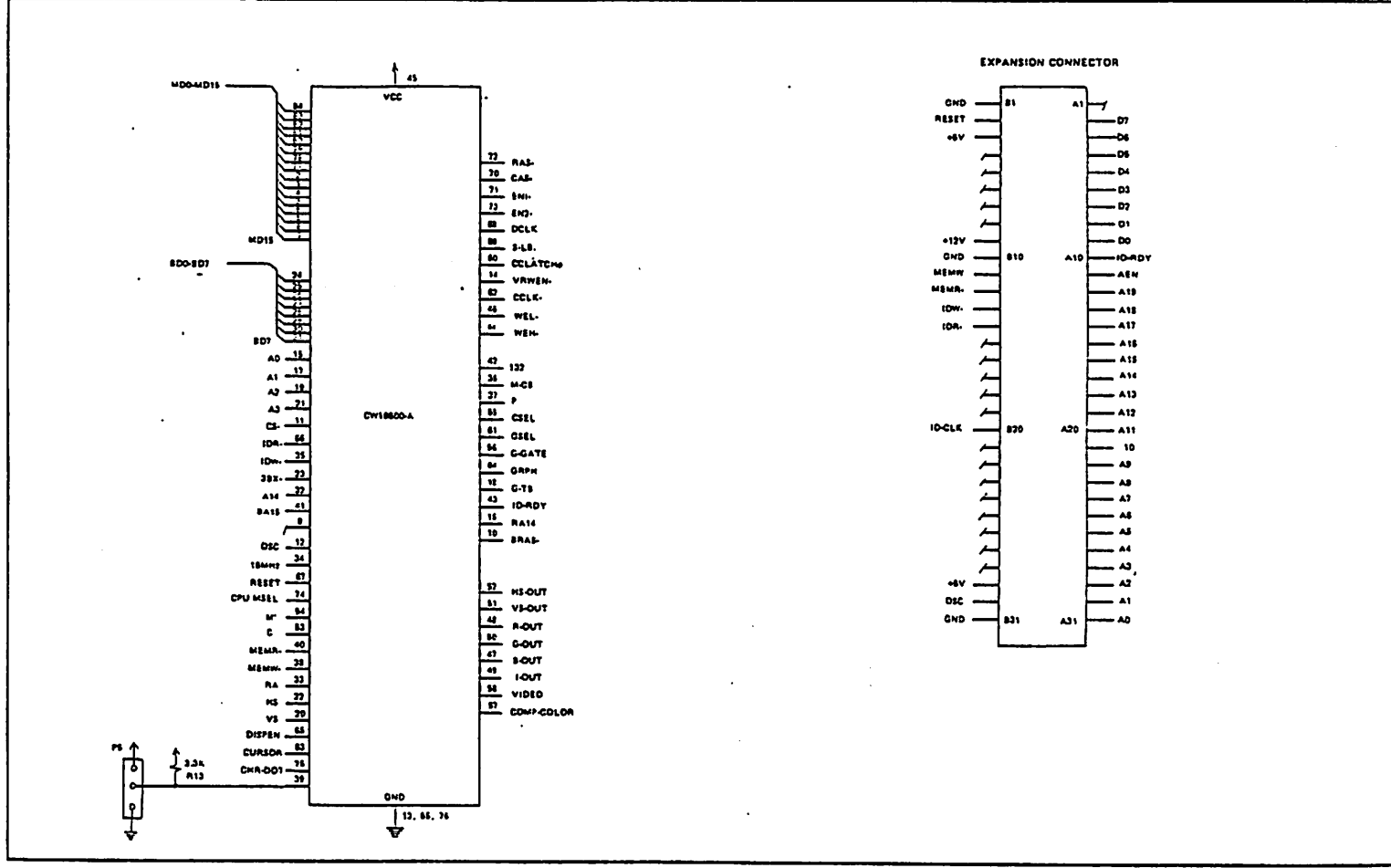

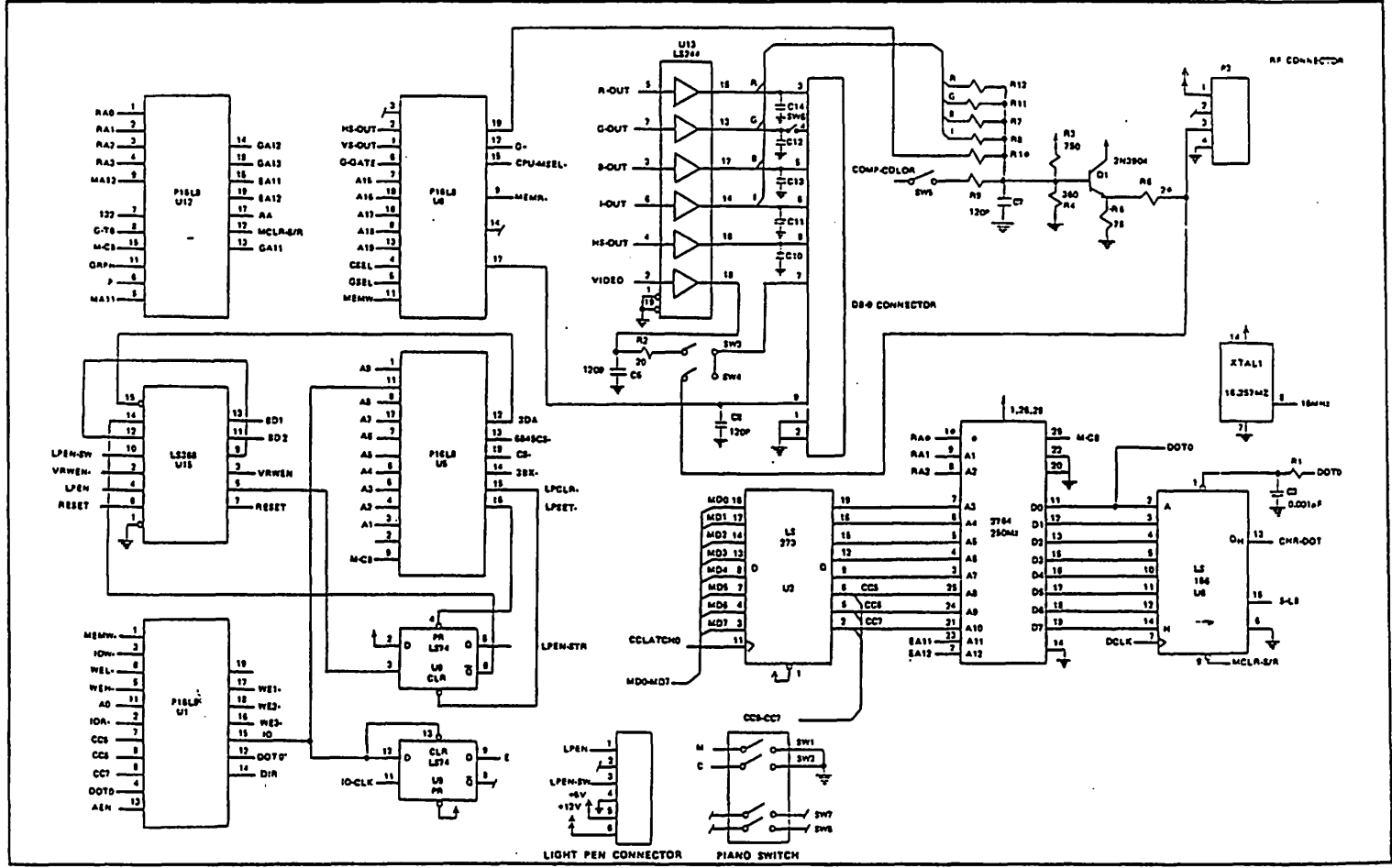



Appendix A

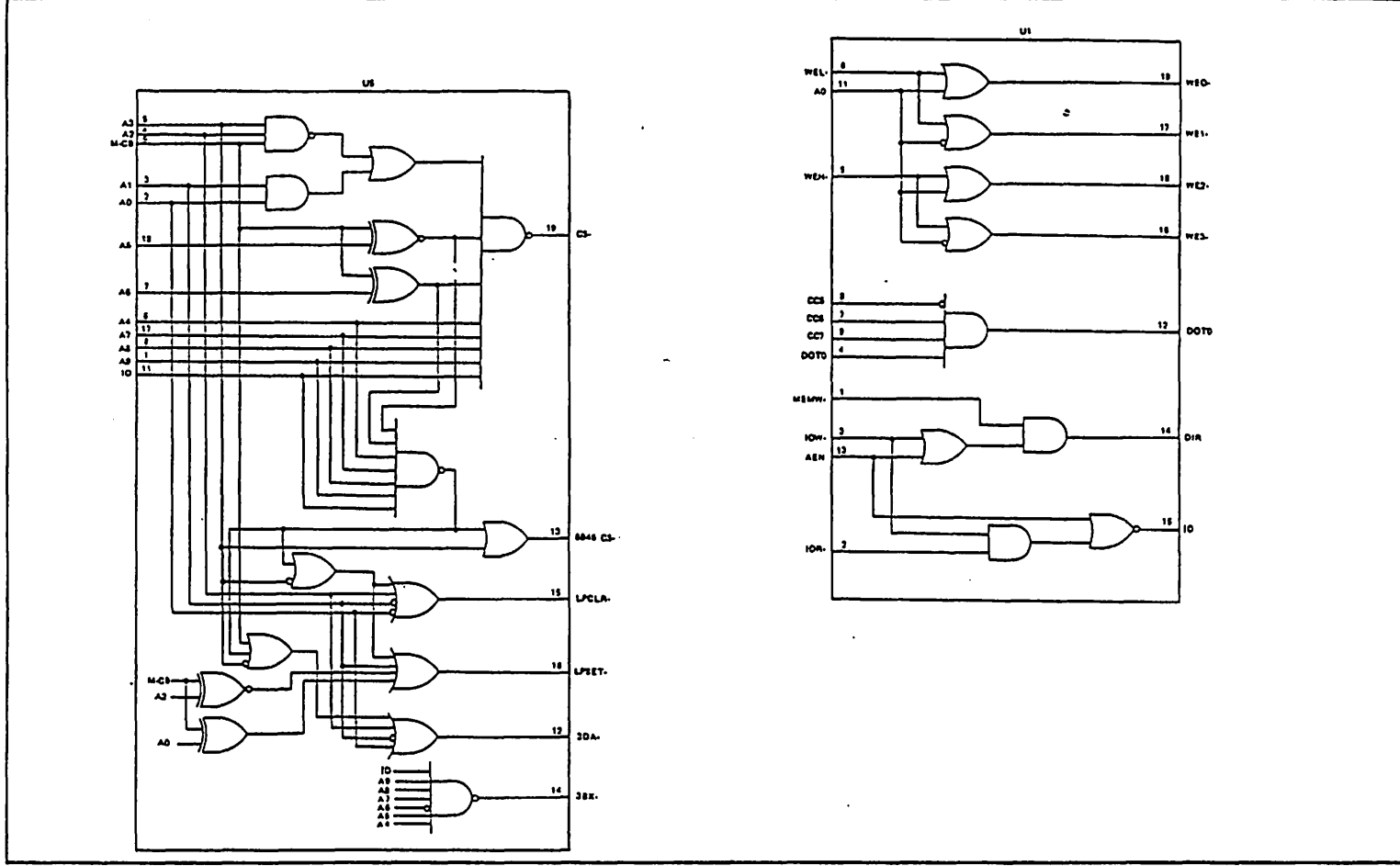

# Schematics

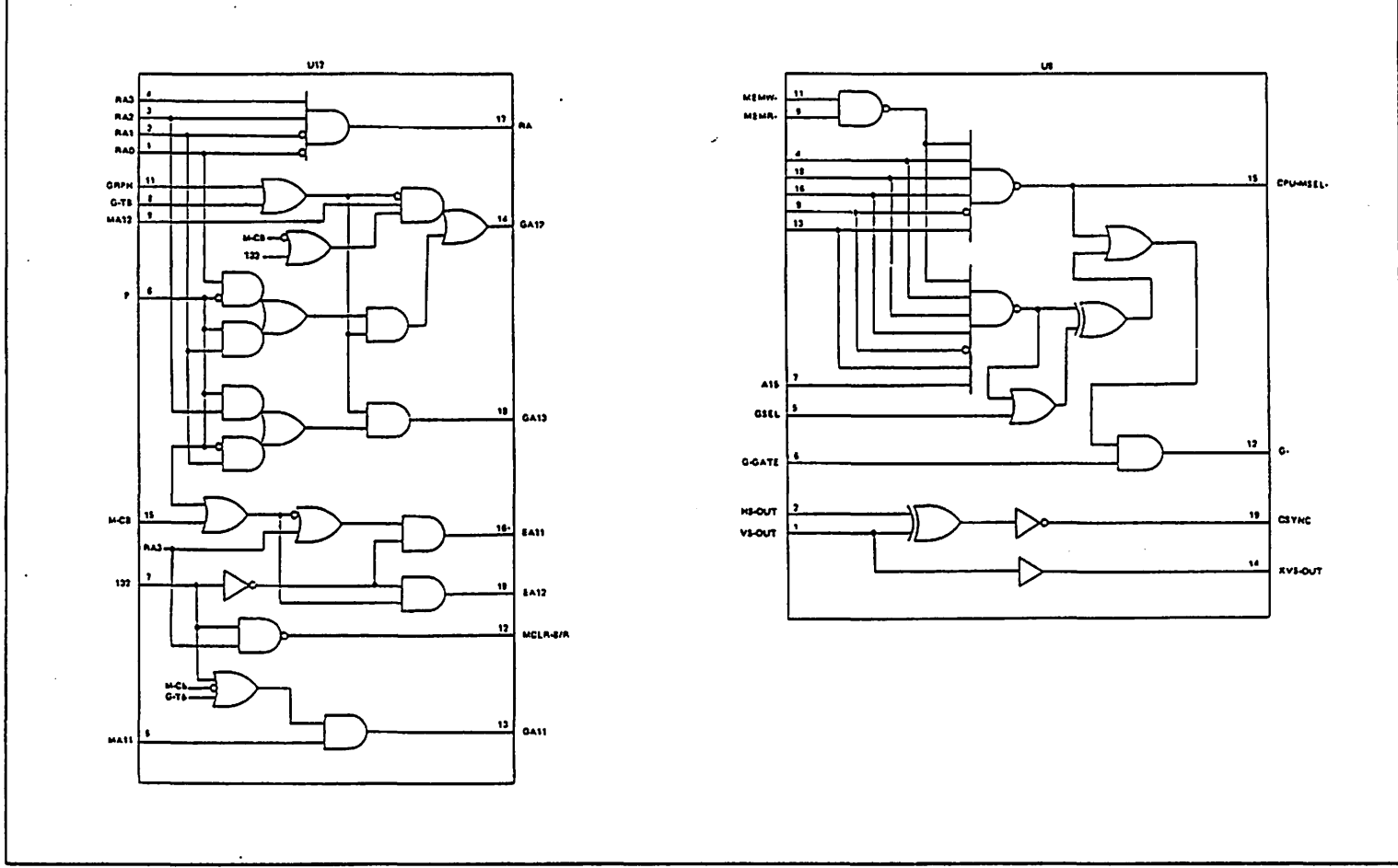

# Appendix A

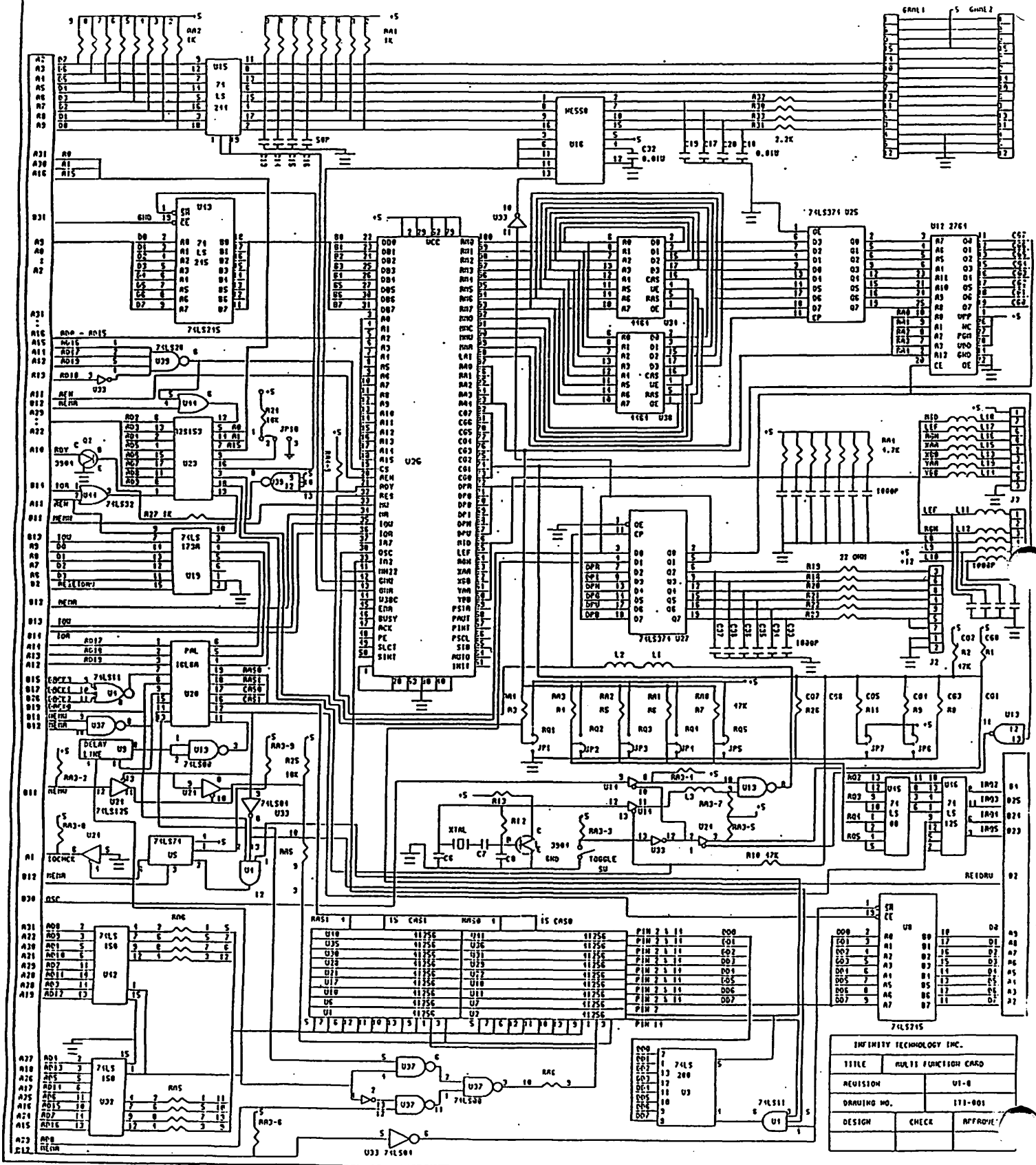



## Index

Advanced diagnostics	2--5 to 2--58
acceptable quality level (def)	2--5
classification of defects	2--8
cosmetic related defects	2--12
defect classification table	2--11
environment of audit inspection	2--8
general inspection procedures	2--9
inspection procedures	2--7
lot size accept/reject	2--6
purpose	2--5
reliability testing requirements	2--6
scope	2--5
selection of defects	2--9
VENDEX computer inspection test procedure	2--14
Alignment test	2--21
Associated documentation	1--1
Asynchronous communication port	4--25
connector pinouts	4--26
Back and sides inspection	2--18
Bad RAM error	4--3
BIOS ROM Checksum error	4--1
Boot disk #1	2--20
Classification of defects	2--8
class A - critical defect	2--8
class B - major defect	2--8
class C - minor defect	2--8
Clock speed switch test	2--38
Color monitor inspection procedure	2--53
labels	2--54
packaging	2--54
blue color and purity test	2--55
brightness	2--57
focus test	2--55
color and contrast test (16 color)	2--56
green color and purity test	2--55
high voltage regulation	2--55
jitter test	2--56
misconvergence	2--56
picture size	2--56

## Index

---

red color and purity test . . . . .	2--55
related documents . . . . .	2--53
test equipment . . . . .	2--53
test inspection . . . . .	2--54
visual inspection . . . . .	2--53
Continuity and grounding test . . . . .	2--19
CPU board (figure) . . . . .	4-6
switch settings . . . . .	4-7
CPU board DIP switch settings . . . . .	2--17, 3--1
CPU board figure parts arrangement plan . . . . .	4-5
CPU board specifications . . . . .	4-4
CPU board switch settings . . . . .	4-7
diskette drive (51/4") . . . . .	4-7
math coprocessor . . . . .	4-7
memory . . . . .	4-7
monitor . . . . .	4-7
CPU board test flow chart . . . . .	4-4
CPU PCBA . . . . .	3--1
CPU tests . . . . .	4-4
Defect classification table . . . . .	2--11
classification reference . . . . .	2--15
cosmetic related . . . . .	2--12
functional operation related . . . . .	2--13
internal visual inspection related . . . . .	2--13
packing related . . . . .	2--11
Disk adapter . . . . .	4-23
Disk drive controller (51/4") . . . . .	4-22
pinouts . . . . .	4-24
Disk drive specifications . . . . .	4-25
Diskette drive power requirements . . . . .	4-26
Diskette drive test . . . . .	2--35
DMA controller test . . . . .	2--39
Dysan interrogator backup software . . . . .	2--21
Environment of audit inspection . . . . .	2--8
intensity of illumination . . . . .	2--9
temperature and humidity . . . . .	2--9
visual inspection distance . . . . .	2--9
Error messages and solutions . . . . .	4--3
External and internal views . . . . .	5--1
front panel . . . . .	5-2
interior view . . . . .	5--3
keyboard . . . . .	5--5
rear view . . . . .	5--4
system unit . . . . .	5--1

Final system button up . . . . .	2--44
Fixed disk adapter block diagram . . . . .	4--23
Front panel . . . . .	5--2
interior view . . . . .	5--3
keyboard . . . . .	5--5
rear view . . . . .	5--4
system unit . . . . .	5--1
Functional test inspection . . . . .	2--19
alignment test . . . . .	2--21
boot disk #1 . . . . .	2--20
clock speed switch test . . . . .	2--38
continuity and grounding test . . . . .	2--19
diskette test . . . . .	2--35
DMA controller test . . . . .	2--39
final system button up . . . . .	2--44
joystick test . . . . .	2--41
keyboard test . . . . .	2--33
light pen port test . . . . .	2--25
memory test . . . . .	2--27
parallel port test . . . . .	2--30
power supply test . . . . .	2--20
power up sequence . . . . .	2--20
serial port test . . . . .	2--31
setup . . . . .	2--29
video display test . . . . .	2--34
Functional test setup . . . . .	2--25
General inspection . . . . .	2--9, 2--18, 3--2
Inspection procedures . . . . .	2--7
Interior view . . . . .	5--3
Interrogator backup software . . . . .	2--21
I/O board NMI interrupt error . . . . .	4--3
ITI video board . . . . .	3--1
jumper switch settings . . . . .	2--17, 3--1
Joystick test . . . . .	2--41
Keyboard . . . . .	5--5
test . . . . .	2--33
Keyboard error . . . . .	4--1
Keyboard inspection . . . . .	2--19, 3--2
0 ohm connection . . . . .	3--2
measuring continuity . . . . .	3--2
Keyboard interface connector . . . . .	4--20
Keyboard specifications . . . . .	4--20

# Index

---

LED color inspection . . . . .	2--19
Light pen port test . . . . .	2--25
Memory parity NMI interrupt error . . . . .	4--3
Memory test . . . . .	2--27, 4--2
Monochrome monitor inspection procedure . . . . .	2--48
function test1 . . . . .	2--48
function test 2 (focus) . . . . .	2--48
function test 3 (high resolution) . . . . .	2--51
function test 4 (low intensity) . . . . .	2--51
function test 5 (high voltage resolution) . . . . .	2--51
function test 6 (linearity and focus) . . . . .	2--51
labels . . . . .	2--49
packaging . . . . .	2--49
picture brightness . . . . .	2--51
related documents . . . . .	2--48
tap test . . . . .	2--52
test completion . . . . .	2--52
test equipment . . . . .	2--48
test inspection . . . . .	2--49
visual inspection . . . . .	2--48
Mother board . . . . .	4--15
expansion slot specifications . . . . .	4--16
figure parts arrangement plan . . . . .	4--17
pinouts . . . . .	4--16
short test . . . . .	4--15
test flow chart . . . . .	4--18
No scan code from keyboard error . . . . .	4--3
NSTA specification . . . . .	2--14
Option adapters . . . . .	4--30
memory expansion unit . . . . .	4--30
Parallel port . . . . .	4--21
pinouts . . . . .	4--21
test . . . . .	2--30
test plug . . . . .	4--29
Parts list . . . . .	4--30
PCBA inspection . . . . .	2--16, 3--1
ITI video . . . . .	3--1
Power connector pinouts . . . . .	4--11
Power-On Self Test . . . . .	4--1
errors . . . . .	4--1
screen display . . . . .	4--1
Power supply . . . . .	4--11

errors	4-1
screen display	4-1
Power supply	4-11
power connector pinouts	4-11
specifications	4-13
test	2-20
test flow chart	4-12
Power supply inspection	2-17, 3-2
Power up sequence	2-20
Printer adapter	4-21
Problem isolation inspection	3-1
Problem isolation procedure	4-1
Problem solving questions	4-2
Real-time clock	4-19
block diagram	4-19
specifications	4-19
Rear view	5-4
Reliability testing	2-7
burn-in	4-7
HI-pot tests	4-7
Required tools and supplies	1-3
RS-232 serial port test	2-31
Selection of defects	2-9
Serial port	4-27
pinouts	4-28
test	2-31
test plug	4-29
Software inspection	2-45
Headstart diskettes	2-45
Standard system configuration	1-2
Stuck scan code	4-3
System unit	5-1
Test equipment	2-14
Test plug	
parallel port	4-29
serial port	4-29
Timer counter error	4-1
Unaccepted HW interrupt error	4-3
VENDEX computer inspection test procedure	2-14
back and sides inspection	2-18
bottom inspection	2-16

## Index

---

defect classification references . . . . .	2--15
functional test inspection . . . . .	2--19
general inspection . . . . .	2--18
keyboard inspection . . . . .	2--19
LED color inspection . . . . .	2--19
monochrome monitor inspection procedure checklist . . . . .	2--60
PCBA inspection . . . . .	2--16
power supply inspection . . . . .	2--17
related documents . . . . .	2--14
test equipment . . . . .	2--14
top cover inspection . . . . .	2--16
visual inspection . . . . .	2--15
wiring and cable inspection . . . . .	2--18
<b>Video display adapters</b>	
checkout routine . . . . .	4--10
<b>Video display test . . . . .</b>	<b>2--34</b>
<b>Wiring and cable inspection . . . . .</b>	<b>2--18</b>
<b>Wrap plugs . . . . .</b>	<b>4--29</b>
parallel port . . . . .	4--29
serial port . . . . .	4--29